

DETAIL T

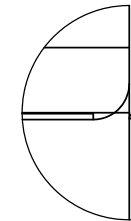
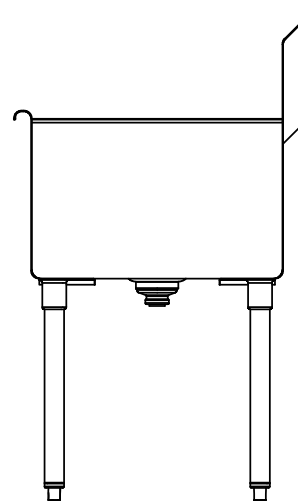
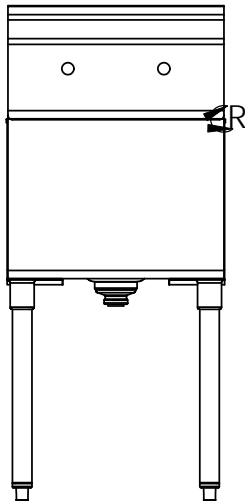
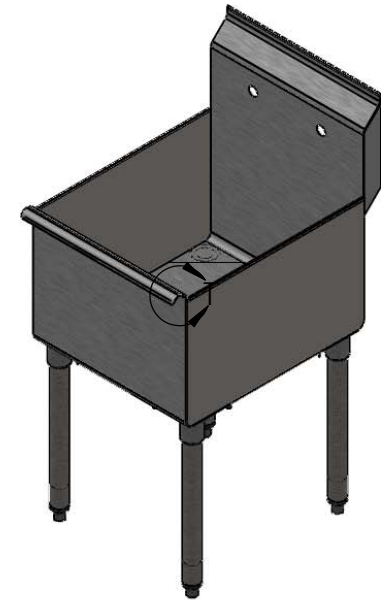

DETAIL R

By signing this document an agreement has been made to begin fabrication of above shown equipment that cannot be reversed. A contract with Aero Mfg. Co. is agreed and equipment is non-cancellable nor returnable.

APPROVED
APPROVED AS NOTED
RESUBMIT AS NOTED

SIGNATURE: _____ DATE: _____

PROPRIETARY AND CONFIDENTIAL

The information contained in this drawing is the sole property of Aero Mfg. Co. Any reproduction in part or as a whole is prohibited.

UNLESS OTHERWISE SPECIFIED:

TOLERANCES:
 FRACTIONAL: ± 1/4
 DECIMAL: ± 0.25
 ANGULAR: ± 1 DEG.

ITEM NO.: D

QUANTITY:

	NAME	DATE
DRAWN:	VM	06.02.11
CHECKED:		

MODEL NO.:
 1 COMP. NON NSF SINK

SHEET SIZE: **A**

SCALE: 1:16



AERO MANUFACTURING CO.
CLIFTON, NJ 07012
 PHONE: 800.237.6634 FAX: 973.473.3794
 WEBSITE: AEROMFG.COM

CUSTOMER:

DWG. NO. **SQUARE CORNER SINK**

SHEET 1 OF 6

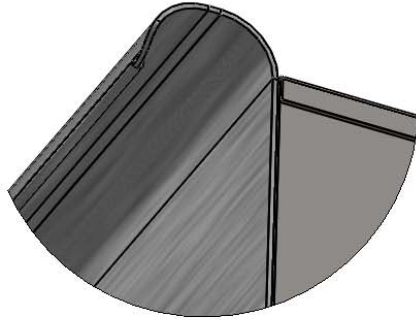

DETAIL W



DETAIL Y

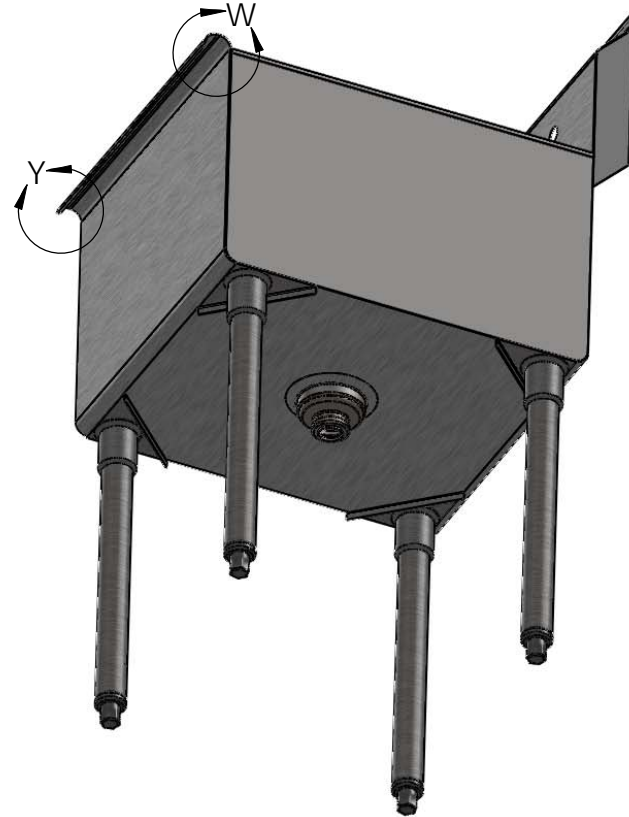

By signing this document an agreement has been made to begin fabrication of above shown equipment that cannot be reversed. A contract with Aero Mfg. Co. is agreed and equipment is non-cancellable nor returnable.

APPROVED
APPROVED AS NOTED
RESUBMIT AS NOTED

SIGNATURE: _____ DATE: _____

PROPRIETARY AND CONFIDENTIAL

The information contained in this drawing is the sole property of Aero Mfg. Co. Any reproduction in part or as a whole is prohibited.

UNLESS OTHERWISE SPECIFIED:

TOLERANCES:
 FRACTIONAL: $\pm 1/4$
 DECIMAL: ± 0.25
 ANGULAR: ± 1 DEG.

ITEM NO.: D

QUANTITY:

NAME DATE

DRAWN: VM 06.02.11

CHECKED:

MODEL NO.:
 1 COMP. NON NSF SINK

SHEET SIZE: **A**

SCALE: 1:16



AERO MANUFACTURING CO.
CLIFTON, NJ 07012
 PHONE: 800.237.6634 FAX: 973.473.3794
 WEBSITE: AEROMFG.COM

CUSTOMER:

DWG. NO. **SQUARE CORNER SINK**

SHEET 2 OF 6