



Assembly Instructions
Instructions de montage
Instrucciones de armado

DATE STAMP

CONTACT US FIRST



WEBSITE

www.prepacmfg.com/content/replacement-part-order
 Complete our easy to use order form



BY EMAIL

parts@prepacmfg.com



BY PHONE

1-877-PREPAC1 (1-877-773-7221)
 Mon - Fri: 7am - 4pm PST / 10am - 7pm EST

We Can Assist

- If you have received a damaged or defective part
- If you are missing hardware or parts
- For help with assembly

Replacement parts will leave our facility within two business days via UPS ground or mail. Please note: shipping times will vary depending on location.

Before you call or email, please:

- 1) Record the following information from the shipping label on the outside of the box. You will need it for warranty purposes:
 - Ship To Name
 - Sales Order Number & Retailer Name
- 2) Note the product model number.
- 3) Review the contents of your shipment to determine what you are missing.

Option de service en ligne

Complétez le formulaire *Commande de Pièces de Rechange* disponible dans la section *Soutien à la clientèle* de notre site web : www.prepacmfg.com

- Si vous avez reçu une pièce endommagée ou défectueuse
- Si vous manquez la quincaillerie ou les pièces

Pour parler avec quelqu'un en français, s'il vous plaît contacter votre détaillant.

Opción de servicio en línea

- Si usted ha recibido una parte dañada o defectuosa, o
- Si falta alguna parte o componente

Complete la forma para solicitud de piezas de remplazo en la sección de soporte al cliente en nuestra página web www.prepacmfg.com

O envíenos sus preguntas al correo parts@prepacmfg.com

Para solicitar ayuda en español por favor contacte su distribuidor.

Model / Modèle # SCC-0606-1

Corner Entryway Hall Tree
Portemanteau d'entrée coin
Recibidor Perchero Esquinero

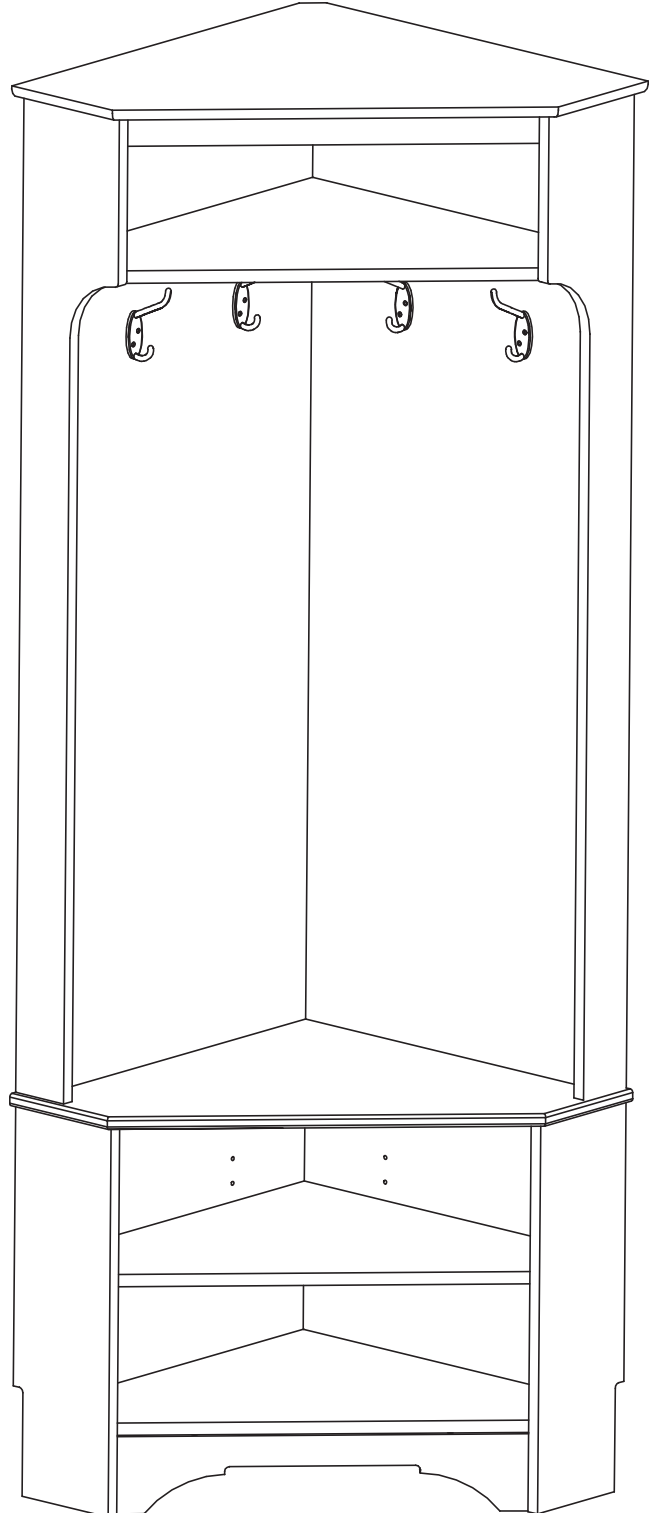

2 Person Assembly
Assemblage par 2 personnes
Conjunto de 2 personas

- C1** Top (1)
Dessus
Superior
TP-10095-D drifted gray / gris vieilli / gris madera
TP-10095-E espresso / espresso
TP-10095-W white / blanc / blanco
- C2** Top Moulding (1)
Moulure supérieure
Moldura superior
TR-10094-D drifted gray / gris vieilli / gris madera
TR-10094-E espresso / espresso
TR-10094-W white / blanc / blanco
- C3** Upper Left Side (1)
Côté gauche supérieur
Lateral izquierdo superior
SL-10097-D drifted gray / gris vieilli / gris madera
SL-10097-E espresso / espresso
SL-10097-W white / blanc / blanco
- C4** Upper Right Side (1)
Côté droit supérieur
Lateral derecho superior
SR-10097-D drifted gray / gris vieilli / gris madera
SR-10097-E espresso / espresso
SR-10097-W white / blanc / blanco
- C5** Upper Fixed Shelf (1)
Etagère fixe supérieure
Estantes fijo superior
SF-10048-D drifted gray / gris vieilli / gris madera
SF-10048-E espresso / espresso
SF-10048-W white / blanc / blanco
- C6** Upper Left Gable (1)
Pignon gauche supérieur
Separadore izquierdo superior
GA-10094-D drifted gray / gris vieilli / gris madera
GA-10094-E espresso / espresso
GA-10094-W white / blanc / blanco
- C7** Upper Right Gable (1)
Pignon droit supérieur
Separadore derecho superior
GA-10095-D drifted gray / gris vieilli / gris madera
GA-10095-E espresso / espresso
GA-10095-W white / blanc / blanco
- C8** Middle Fixed Shelf (1)
Etagère du milieu fixe
Estantes medio fijo
SF-10049-D drifted gray / gris vieilli / gris madera
SF-10049-E espresso / espresso
SF-10049-W white / blanc / blanco
- C9** Lower Left Side (1)
Côté gauche inférieur
Lateral izquierdo inferior
SL-10098-D drifted gray / gris vieilli / gris madera
SL-10098-E espresso / espresso
SL-10098-W white / blanc / blanco
- C10** Lower Right Side (1)
Côté droit inférieur
Lateral derecho inferior
SR-10098-D drifted gray / gris vieilli / gris madera
SR-10098-E espresso / espresso
SR-10098-W white / blanc / blanco
- C11** Lower Left Gable (1)
Pignon gauche inférieur
Separadore izquierdo inferior
GA-10096-D drifted gray / gris vieilli / gris madera
GA-10096-E espresso / espresso
GA-10096-W white / blanc / blanco
- C12** Lower Right Gable (1)
Pignon droit inférieur
Separadore derecho inferior
GA-10097-D drifted gray / gris vieilli / gris madera
GA-10097-E espresso / espresso
GA-10097-W white / blanc / blanco
- C13** Adjustable Shelf (1)
Etagere ajustable
Estante ajustable
SH-10091-D drifted gray / gris vieilli / gris madera
SH-10091-E espresso / espresso
SH-10091-W white / blanc / blanco
- C14** Bottom (1)
Le bas
Bas
BT-10095-D drifted gray / gris vieilli / gris madera
BT-10095-E espresso / espresso
BT-10095-W white / blanc / blanco
- C15** Front Stabilizer / Kicker (1)
Stabilisateur avant
Estabilizador frontal
KR-10068-D drifted gray / gris vieilli / gris madera
KR-10068-E espresso / espresso
KR-10068-W white / blanc / blanco

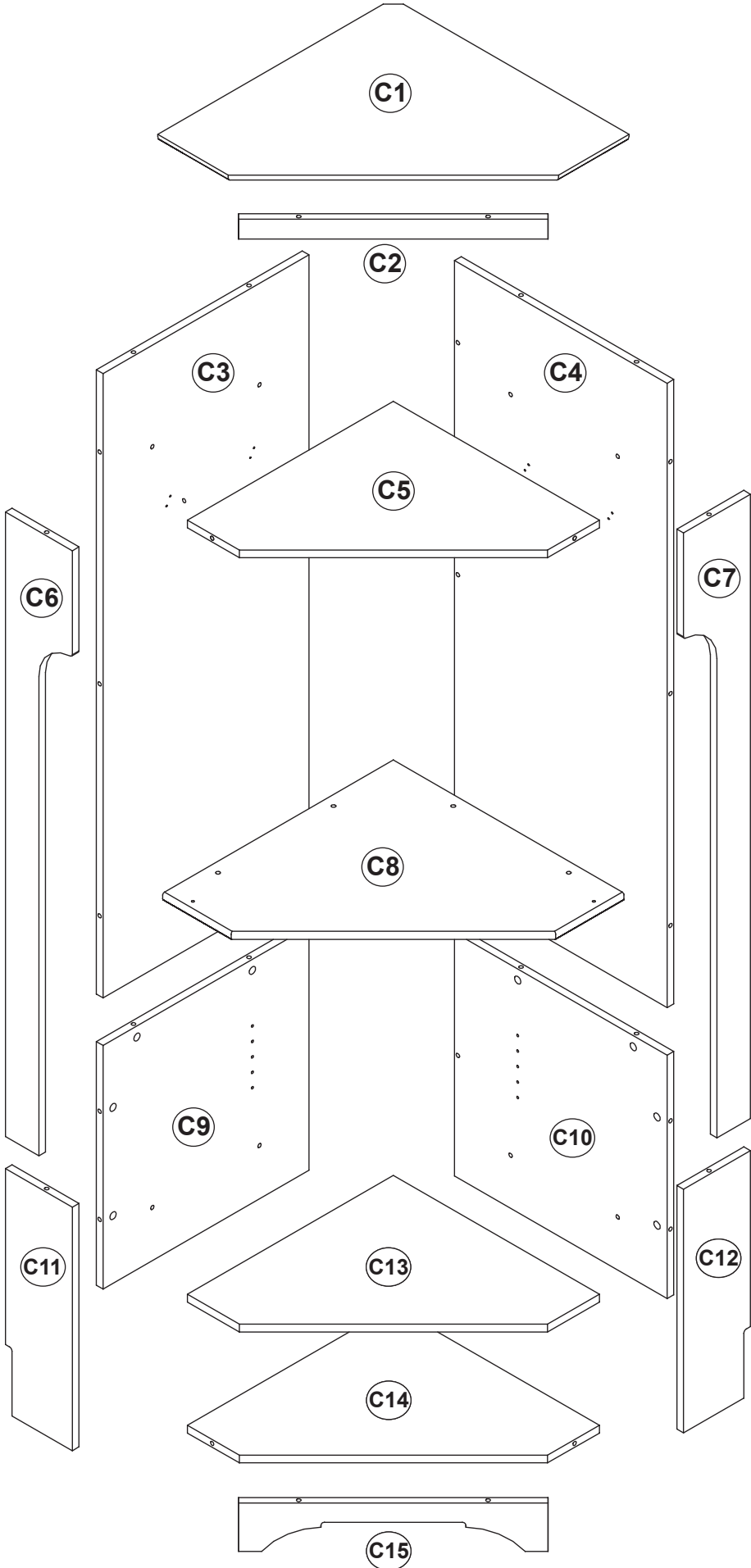

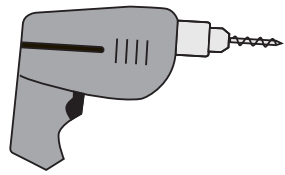
Required Tools / Outils requis / Herramientas necesarias

3/16th inch diameter
3/16^{ème} de pouce de diamètre
3/16 pulgadas de diametro

Caution

Do not over tighten any screw. The last few turns of each screw should be done very slowly or by hand.

Attention

Évitez de trop serrer les vis. Ralentissez la vitesse de la foreuse pour les derniers deux tours de vis ou vissez-les lentement à la main.

Precaución

No apriete los tornillos demasiado. Las últimas vueltas de cada tornillo deben hacerse muy lentamente o con la mano.

**ONLINE HELP**

To see how-to videos, go to the Product Support page on our website:

www.prepacmfg.com/content/assembly

L'AIDE EN LIGNE

Pour visionner les vidéo (en anglais) décrivant l'installation, consultez la page de "Product Support" sur notre site web : www.prepacmfg.com/content/assembly

AYUDA EN LINEA

Para ver videos de ayuda (en inglés), en nuestra pagina web click en las section "Product Support" www.prepacmfg.com/content/assembly

BEFORE YOU BEGIN

Identify ALL parts and hardware to ensure everything is included.

AVANT DE COMMENCER

Identifier toutes les pièces et le matériel afin de s'assurer que tout est inclus.

ANTES DE COMENZAR

Identifique todos las partes y componentes para estar seguro que todo está incluido

Hardware / Quincaillerie / Piezas de Conexión

HP-1086-D - drifted gray / gris vieilli / gris maderá

HP-1086-E - espresso / espresso

HP-1086-W - white / blanc / blanco

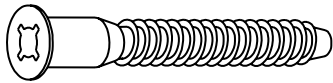

Confirmat Screw (11)
Vis d'assemblage Confirmat
Tornillos Confirmat
RM-0001

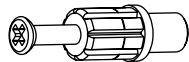

24mm Green Twister Dowel (26)
Goujons verts à visser 24mm
Clavija verde giratoria
RM-0501

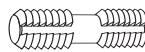

Plastic Dowel (2)
Goujon en plastique
Clavija de plástico
RM-0072



Double Ended Connecting Rod (4)
Vis d'assemblage double
Conector de doble extremo
RM-0567



Shelf Support (4)
Support d'étagère
Soporte para estante
RM-0229 espresso / espresso
RM-0229 drifted gray / gris vieilli / gris maderá
RM-0010 white / blanc / blanco



Coat Hook (4)
Crochet de manteau
Gancho para ropa
RM-0484
chrome / chrome / cromo

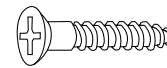

#6 - 5/8" Screw (8)
Vis no. 6 - 5/8 po.
Tornillos de 6-5/8"
RM-0004

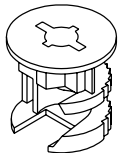

15mm Zinc Cam (large) (34)
Ferrure en zinc grand
Tuercas de fijación grande de zinc
RM-0103



Cam Cover Cap (14)
Capuchons de cames
Cubierta de tuercas
RM-0802 drifted gray / gris vieilli / gris vieilli
RM-0806 espresso / espresso
RM-0809 white / blanc / blanco

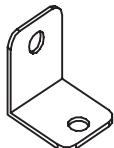

Safety Bracket (1)
Support de sécurité
Ménsula de seguridad
RM-0515



#8 - 9/16" Washerhead Screws (1)
Vis en bois no.8 - 9/16 po.
Tornillos núm.8 de 9/16 pulg.
RM-0521



3 1/2" Quadrex Screw (1)
Vis Quadrex 3 1/2 po.
Tornillo Quadrex de 3 1/2"
RM-0888



Black Coat Hook with screws (4)
Crochet de manteau noir avec des vis
Gancho para ropa negro con tornillos
RM-0484-B

OR / OU / O

Assemble the Top Section
Assembler la section supérieure
Monte la sección superior

1

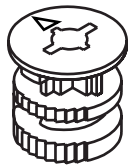
 **x14**
Large Zinc Cam
Ferrure en zinc grand
Tuercas de fijación
grande de zinc

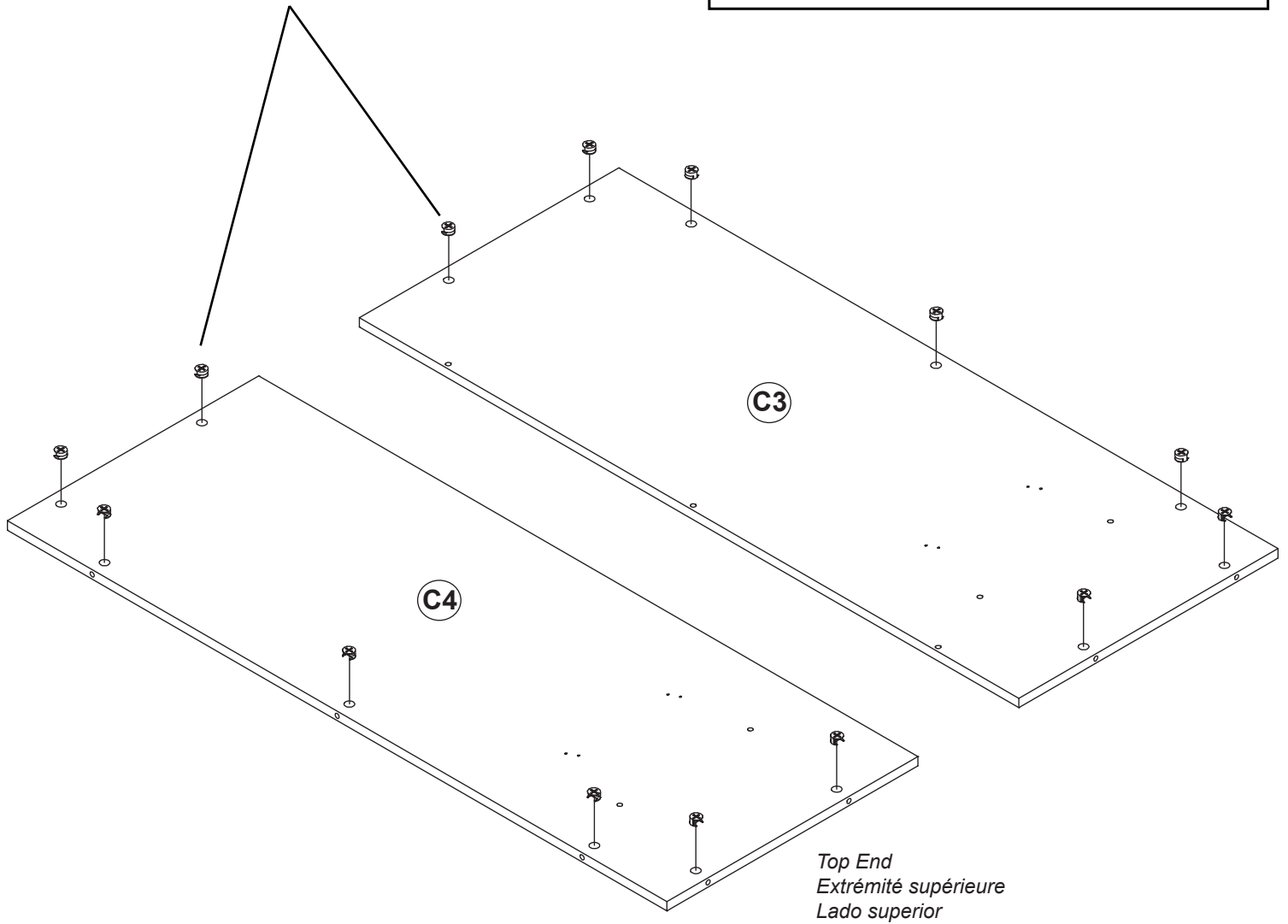
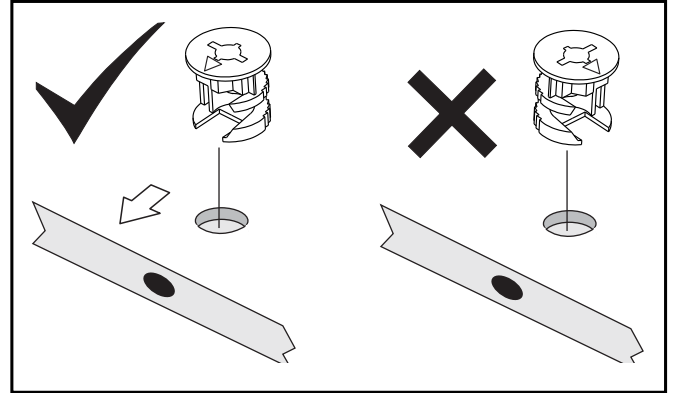

2

x3
Confirmat Screw
Vis d'assemblage Confirmat
Tornillos Confirmat

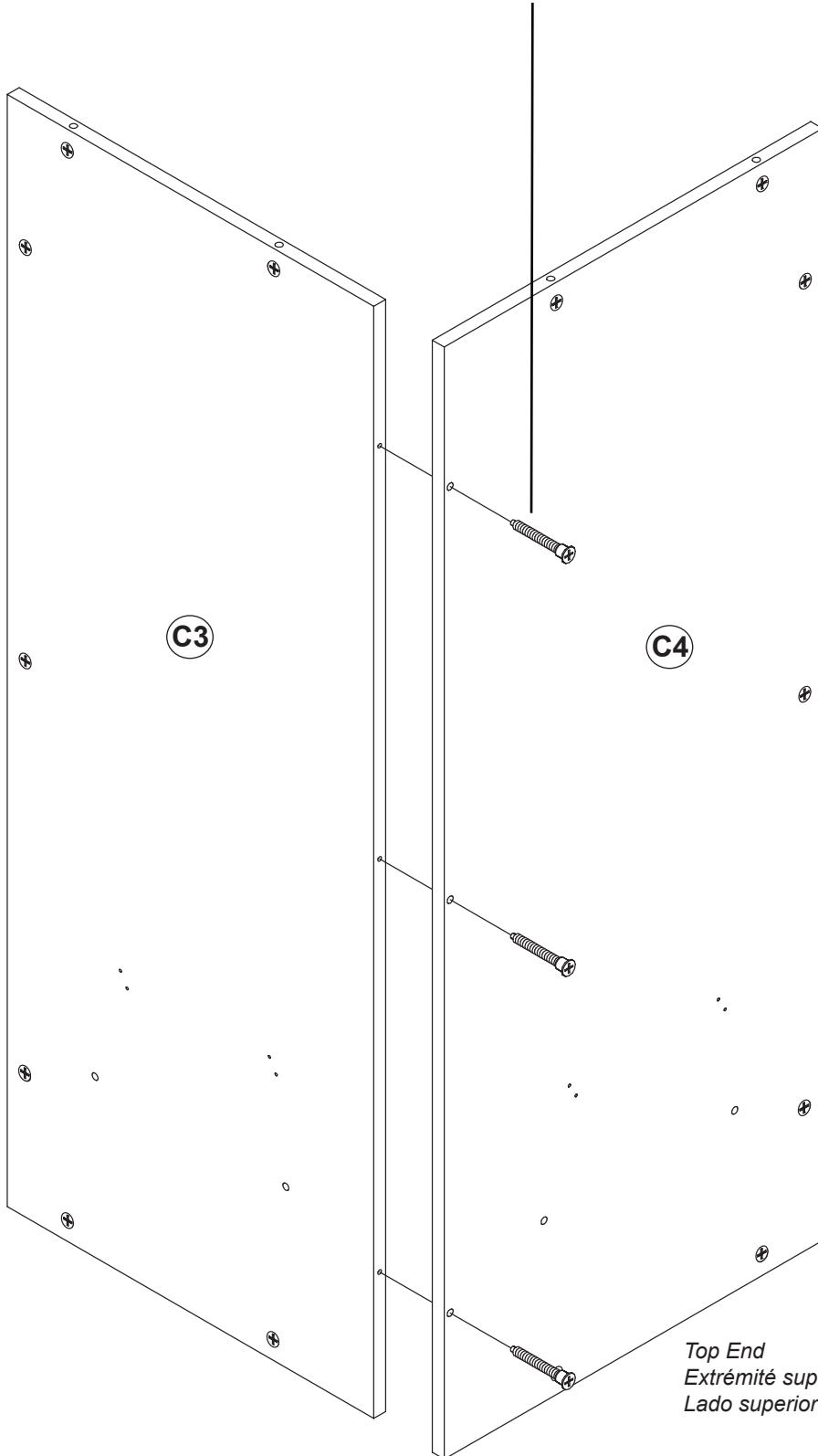

Top End
Extrémité supérieure
Lado superior

3a

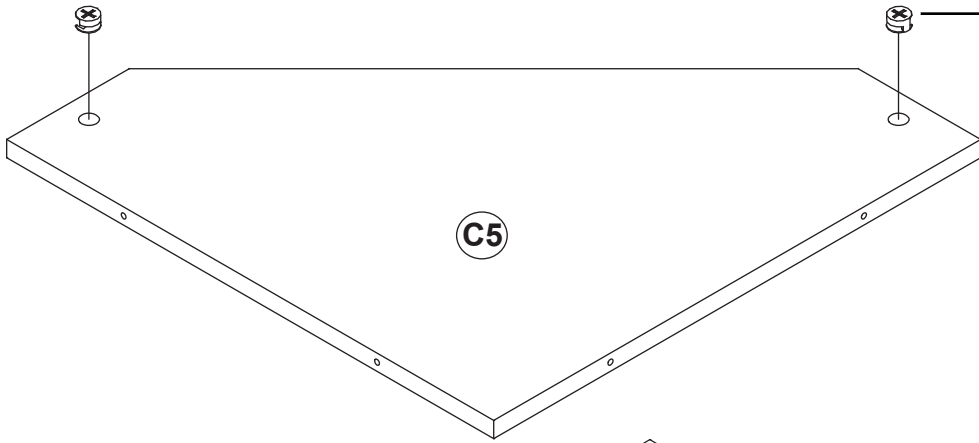

x2
Large Zinc Cam
Ferrure en zinc grand
Tuercas de fijación grande de zinc

3b

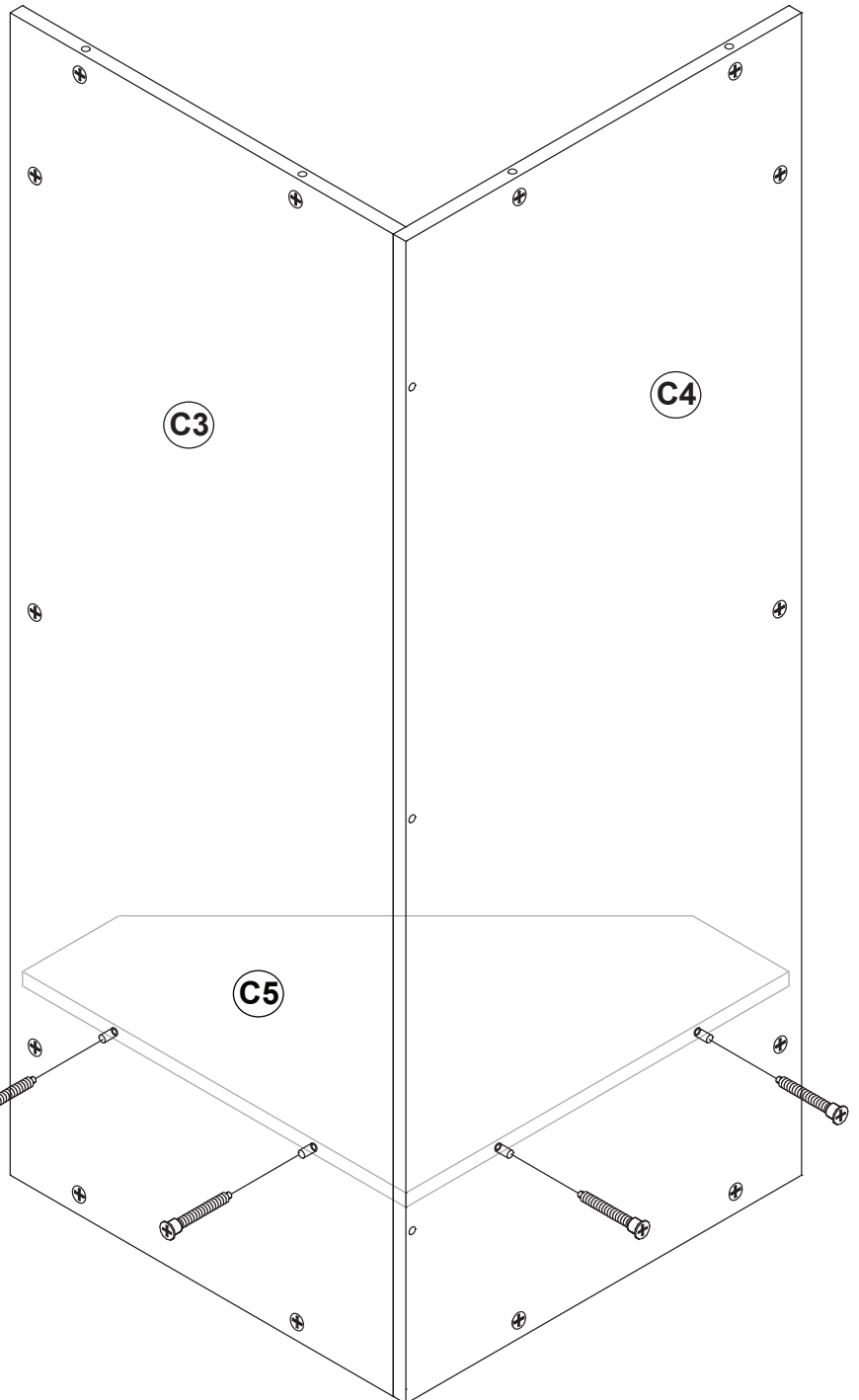

x3
Confirmat Screw
Vis d'assemblage Confirmat
Tornillos Confirmat

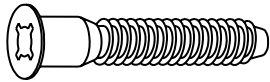

4a

x 8
 24mm Green Twister Dowel
 Goujons verts à visser 24mm
 Clavija verde giratoria

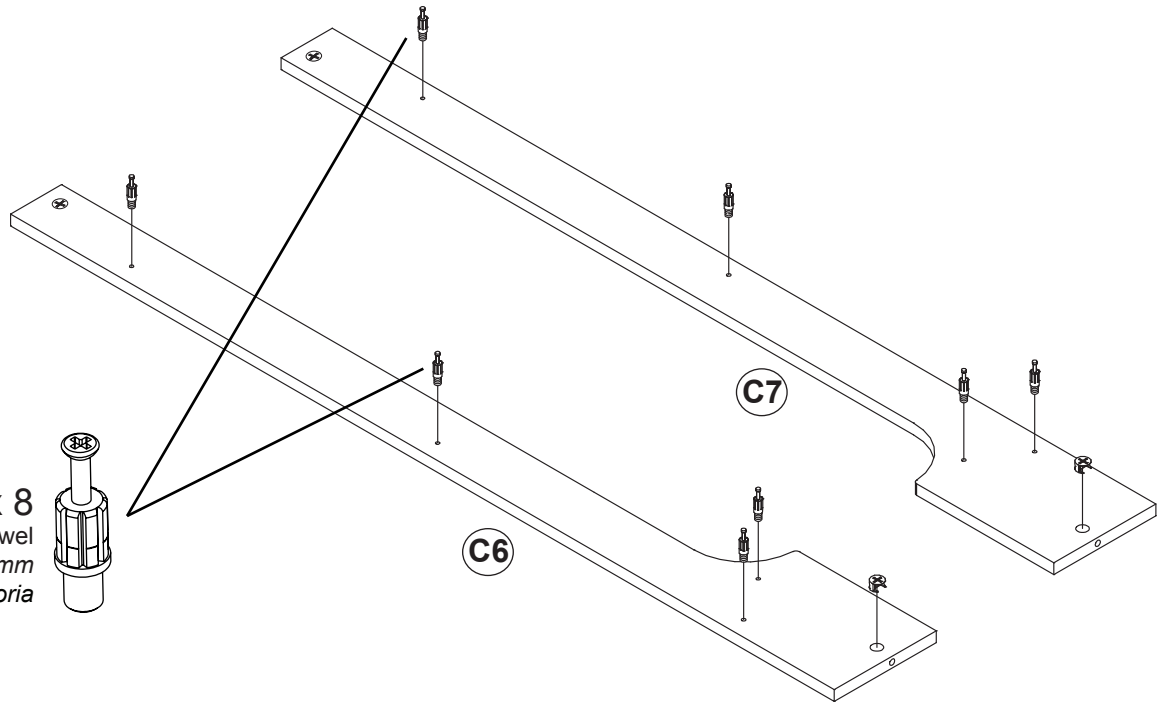

4b

x8

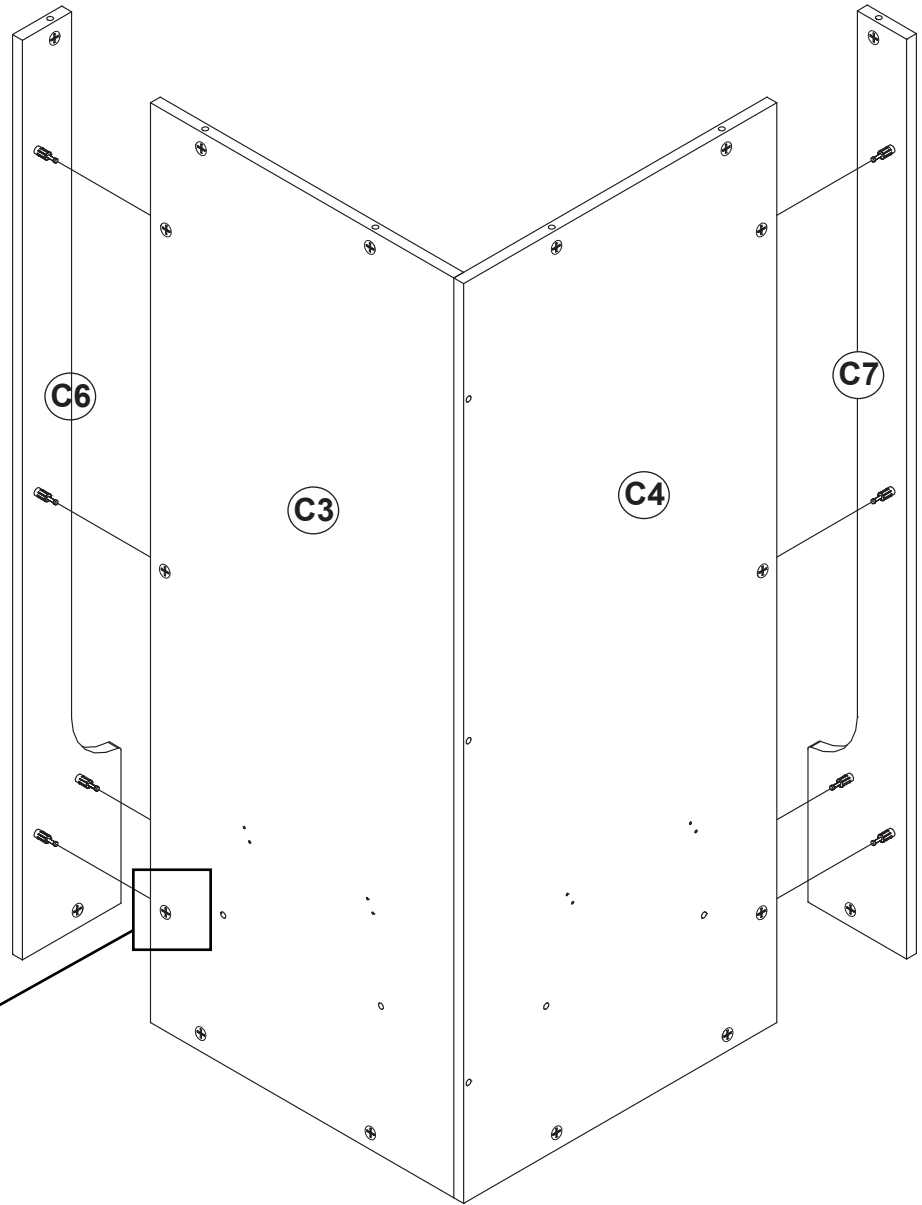

Lock the Cams
Serrez les ferrures
Asegure las tuercas de fijación

Unlocked
deverrouillé
abierta

Locked: Turn 210°
Verrouillé: tournez 210°
Cerrada: gire 210 grados

5a

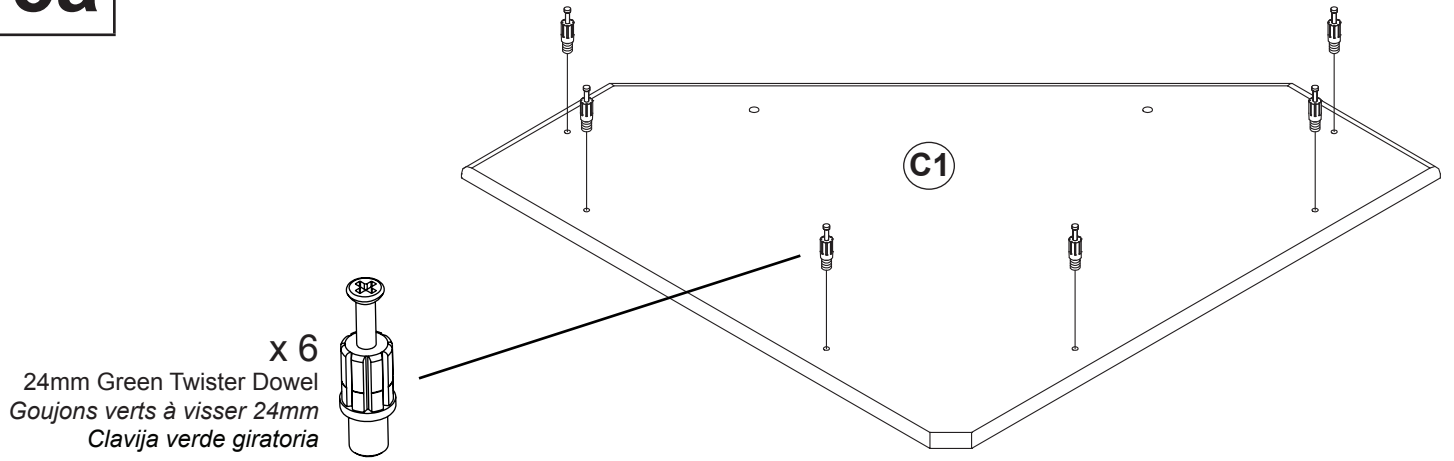

5b

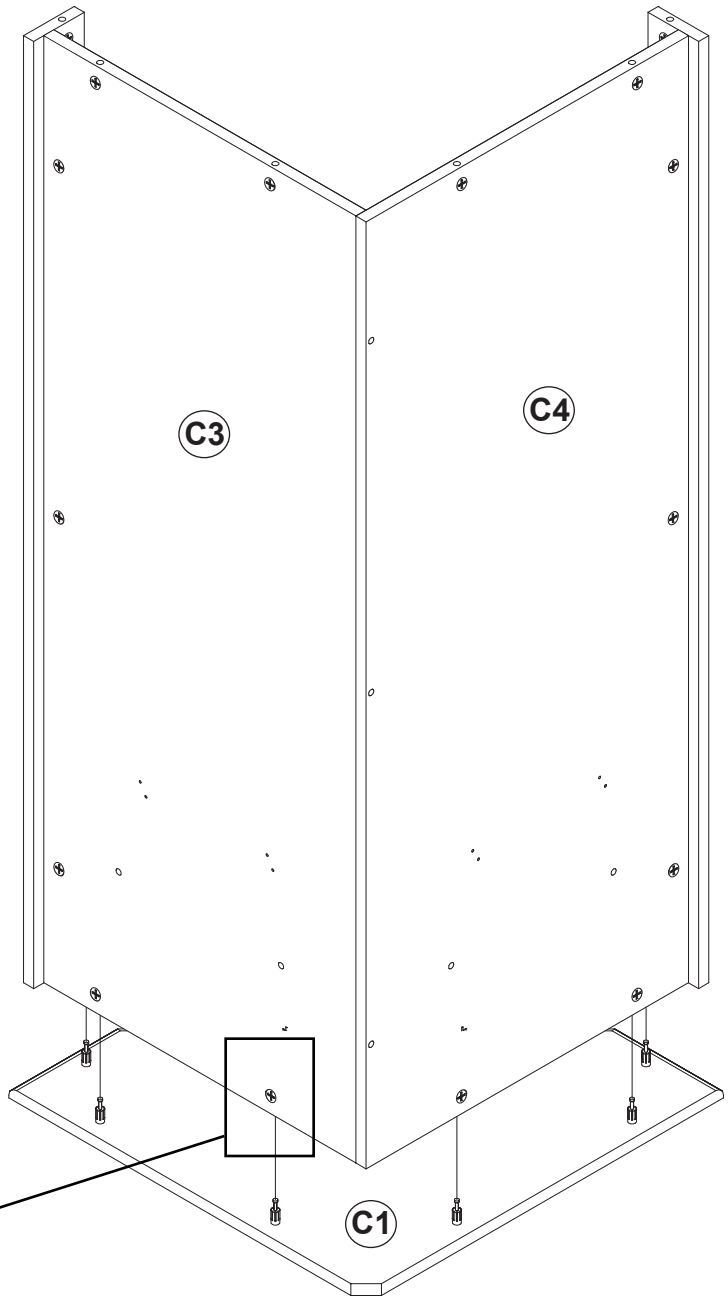

6a

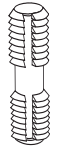

x2
Plastic Dowel
Goujon en plastique
Clavija de plastico

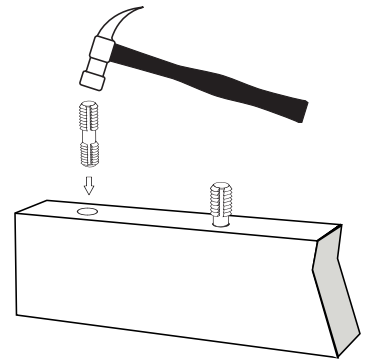
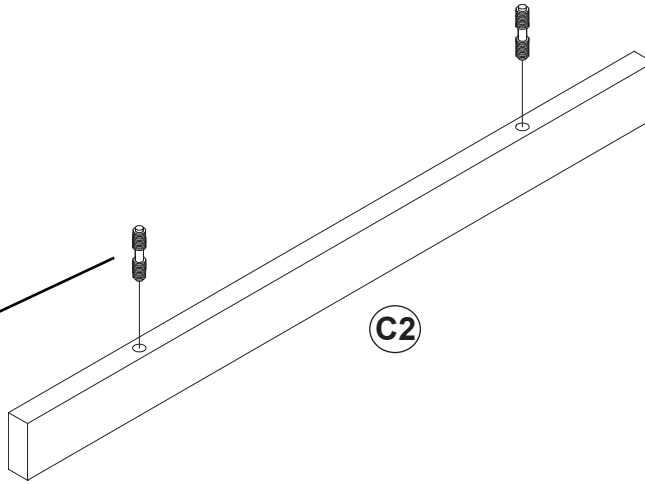

Insert halfway ONLY
Insérez à mi-chemin seulement
Inserte SOLAMENTE la mitad

6b

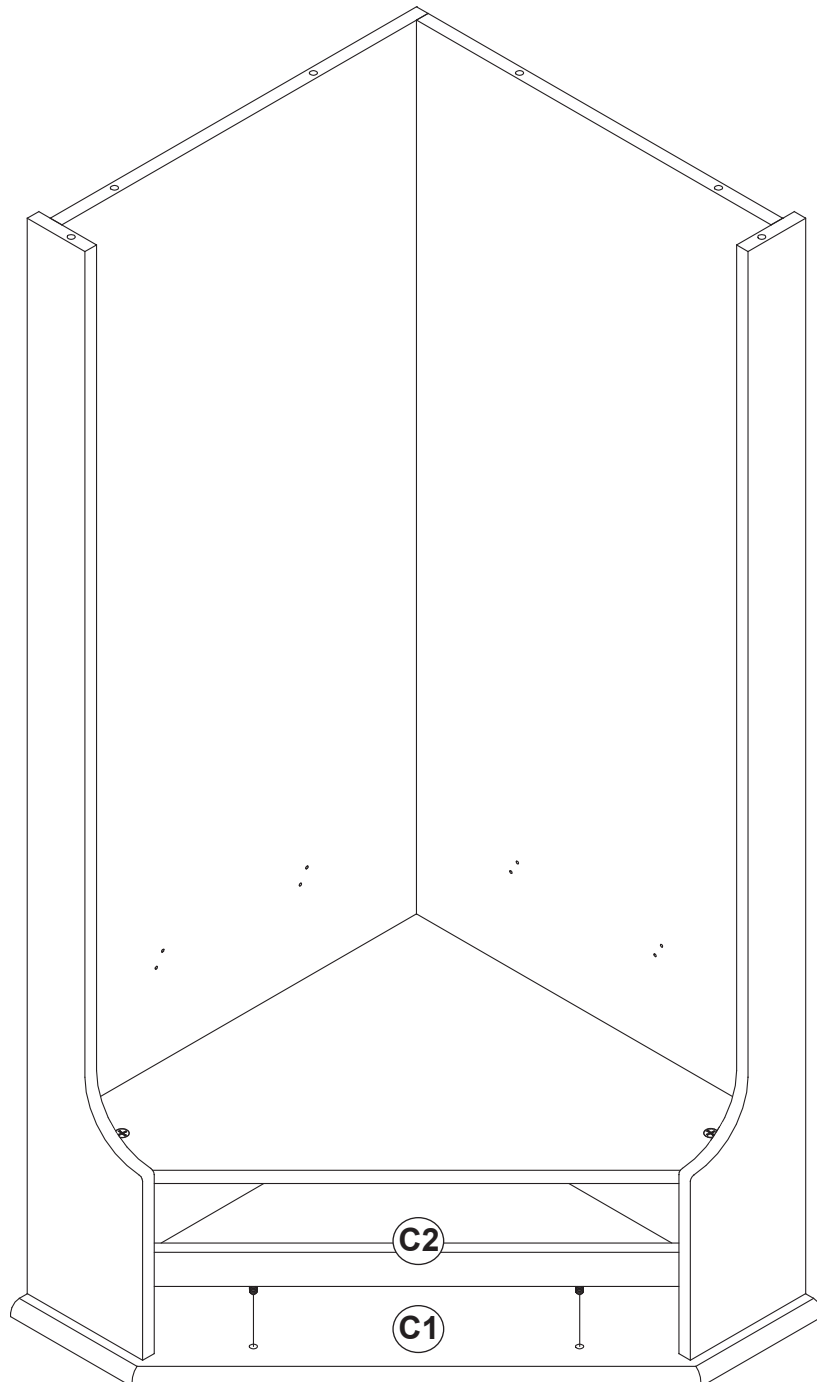
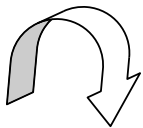

7a

Bottom Side
Côté inférieur
Lado inferior

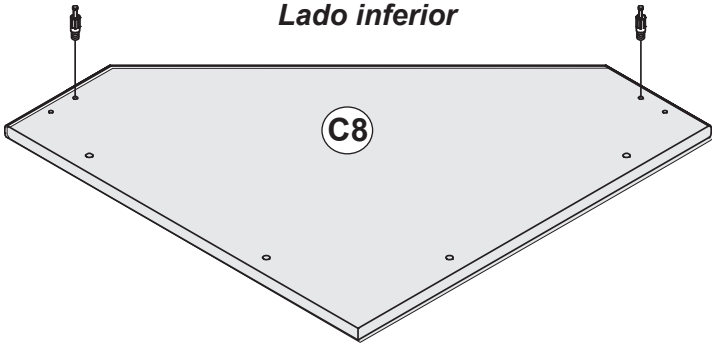

Top Side
Côté supérieur
Lado superior

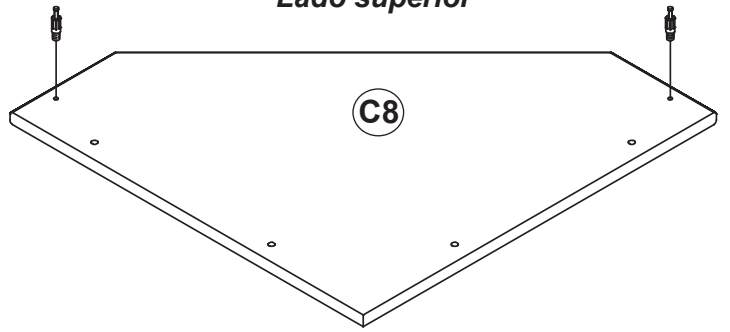

7b



x4
Double Ended
Connecting Rod
Vis d'assemblage double
Conector de doble extremo

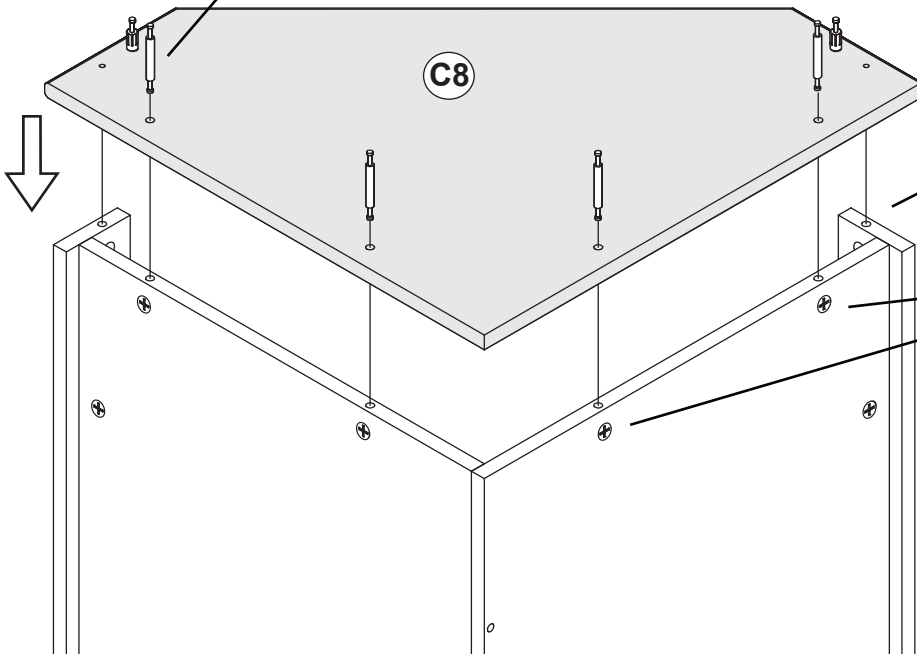

x6

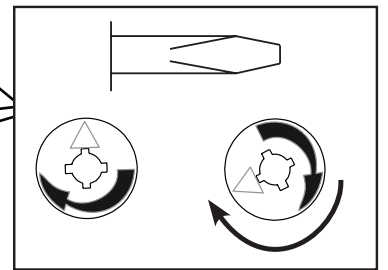

7c

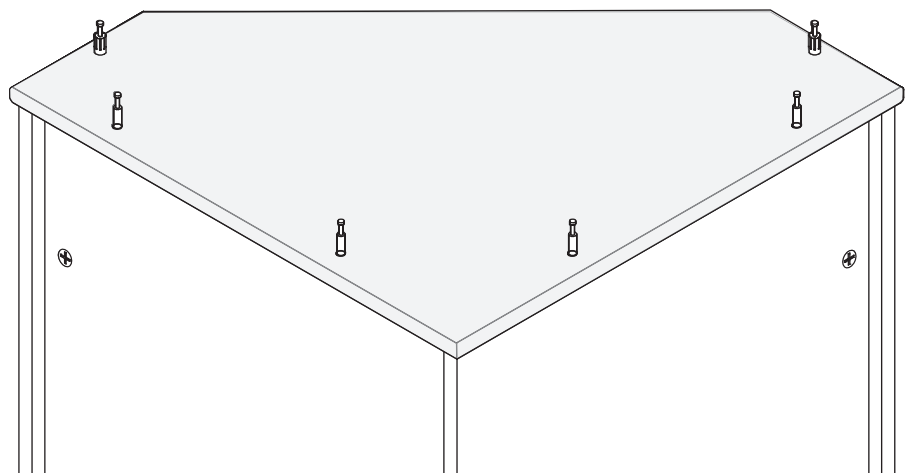

Assemble the Bottom Section
Assembler la section inférieure
Monte la sección inferior

8a

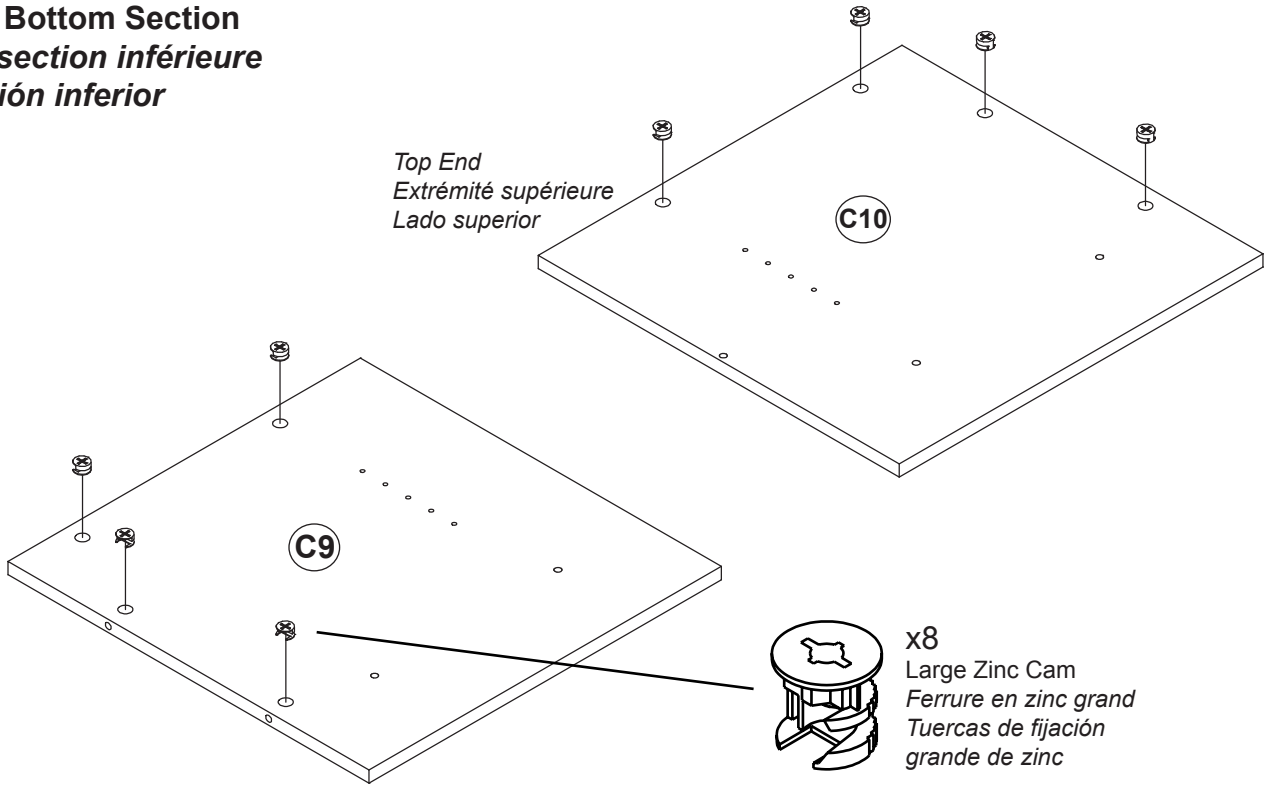

8b

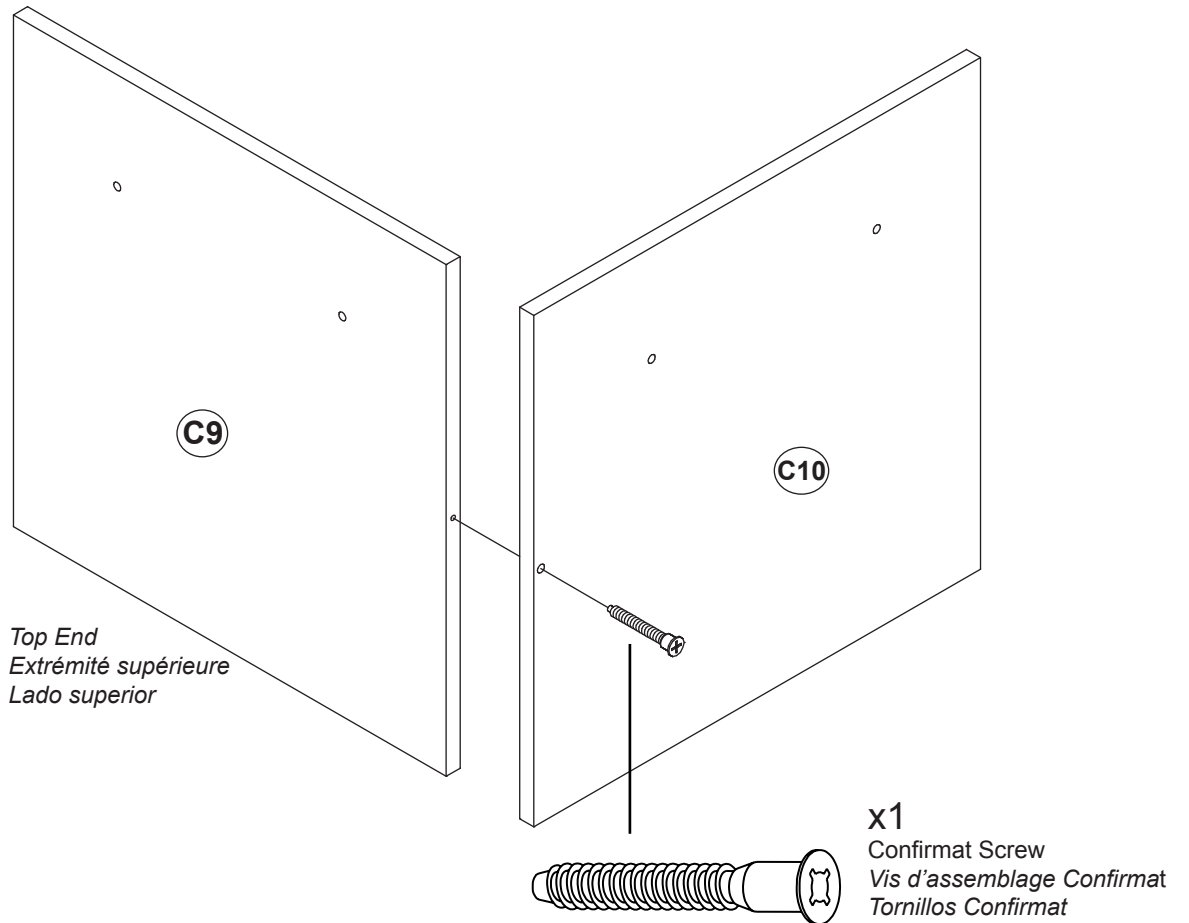

9a

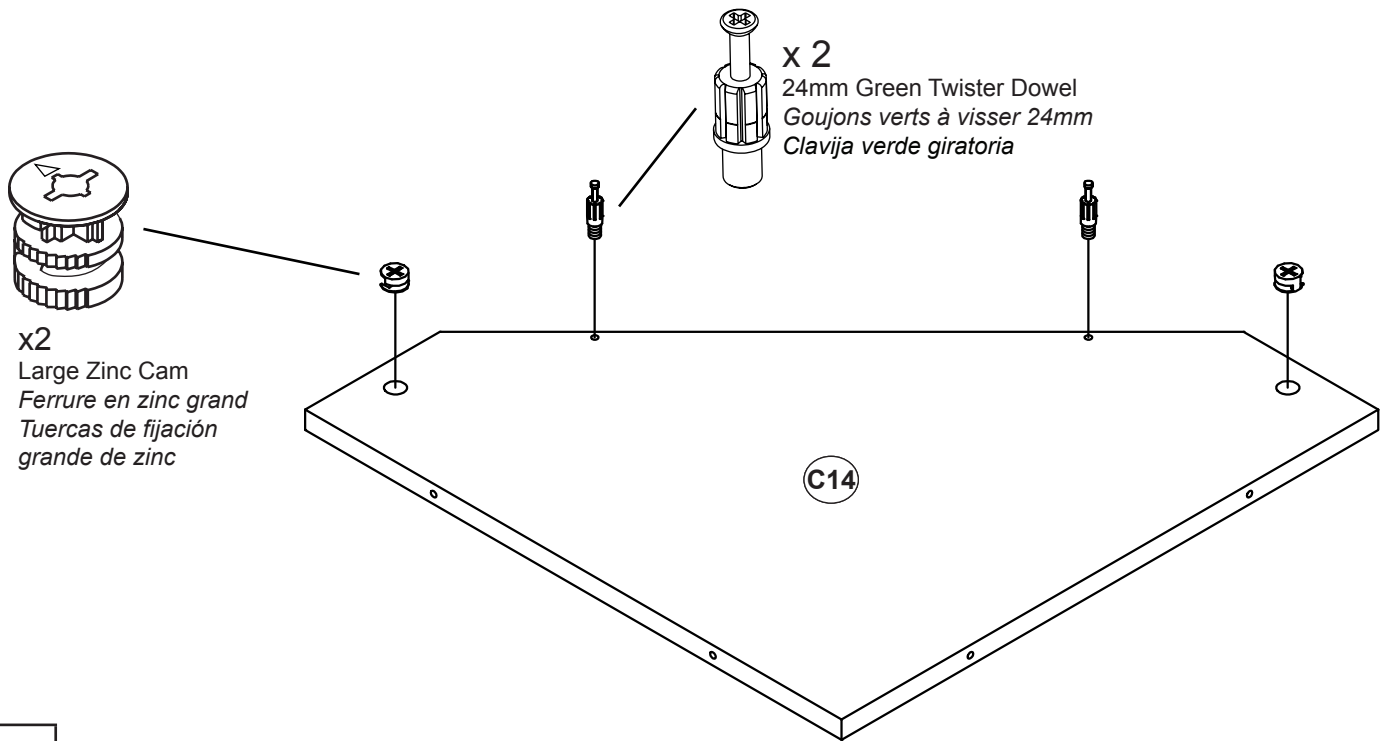

9b

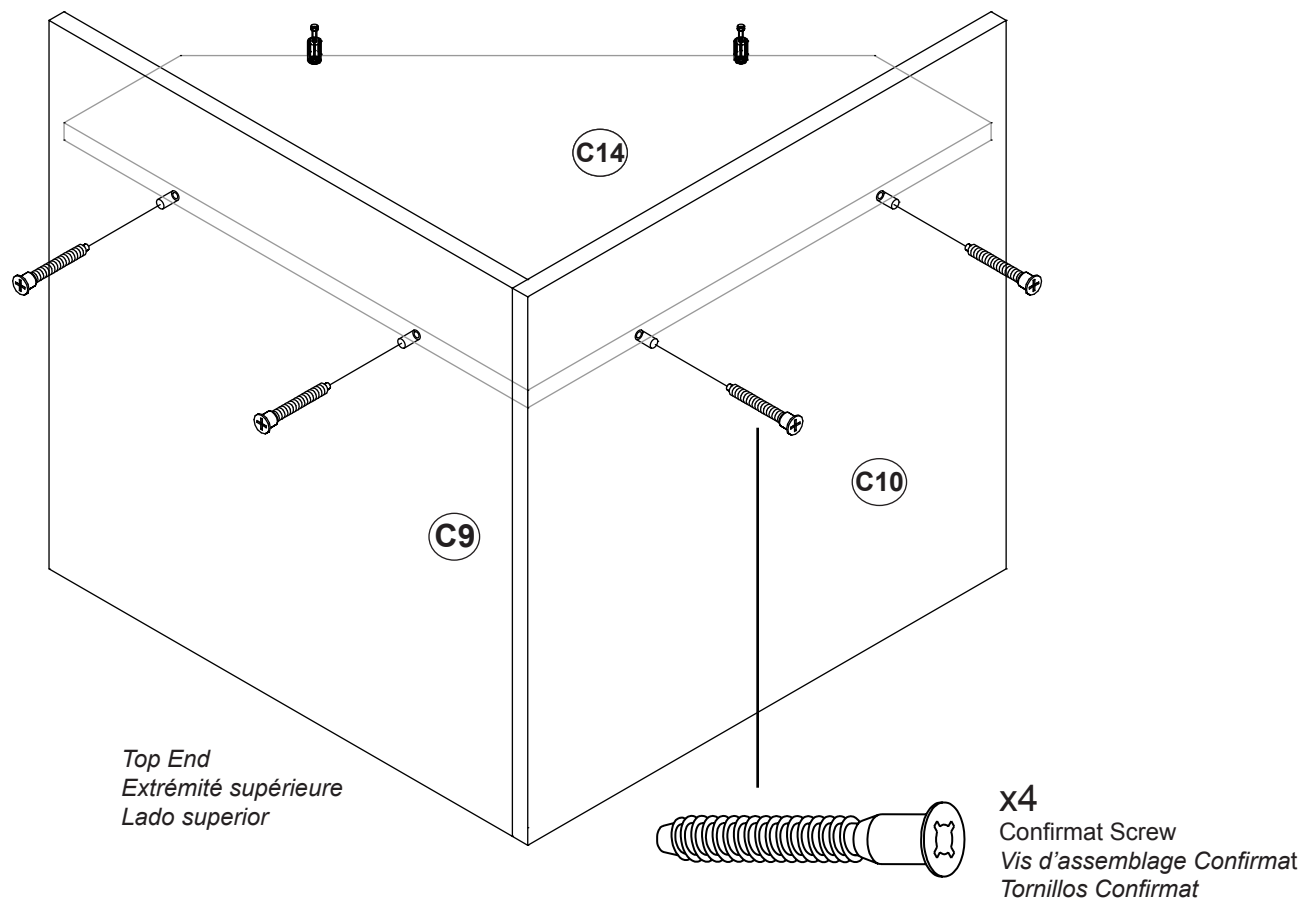

10a

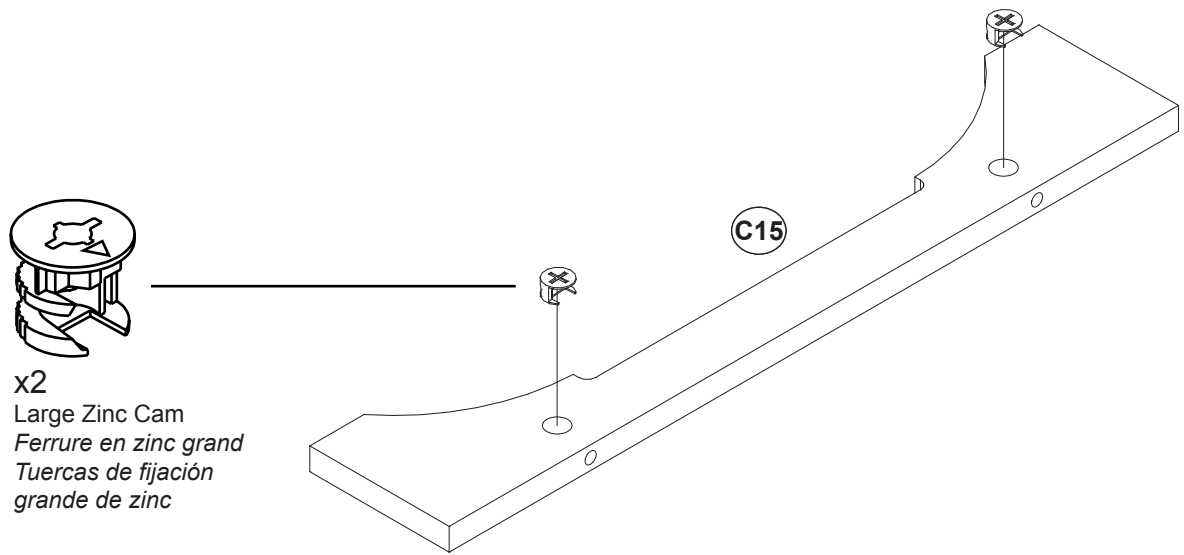

x2
Large Zinc Cam
Ferrure en zinc grand
Tuercas de fijación
grande de zinc

10b

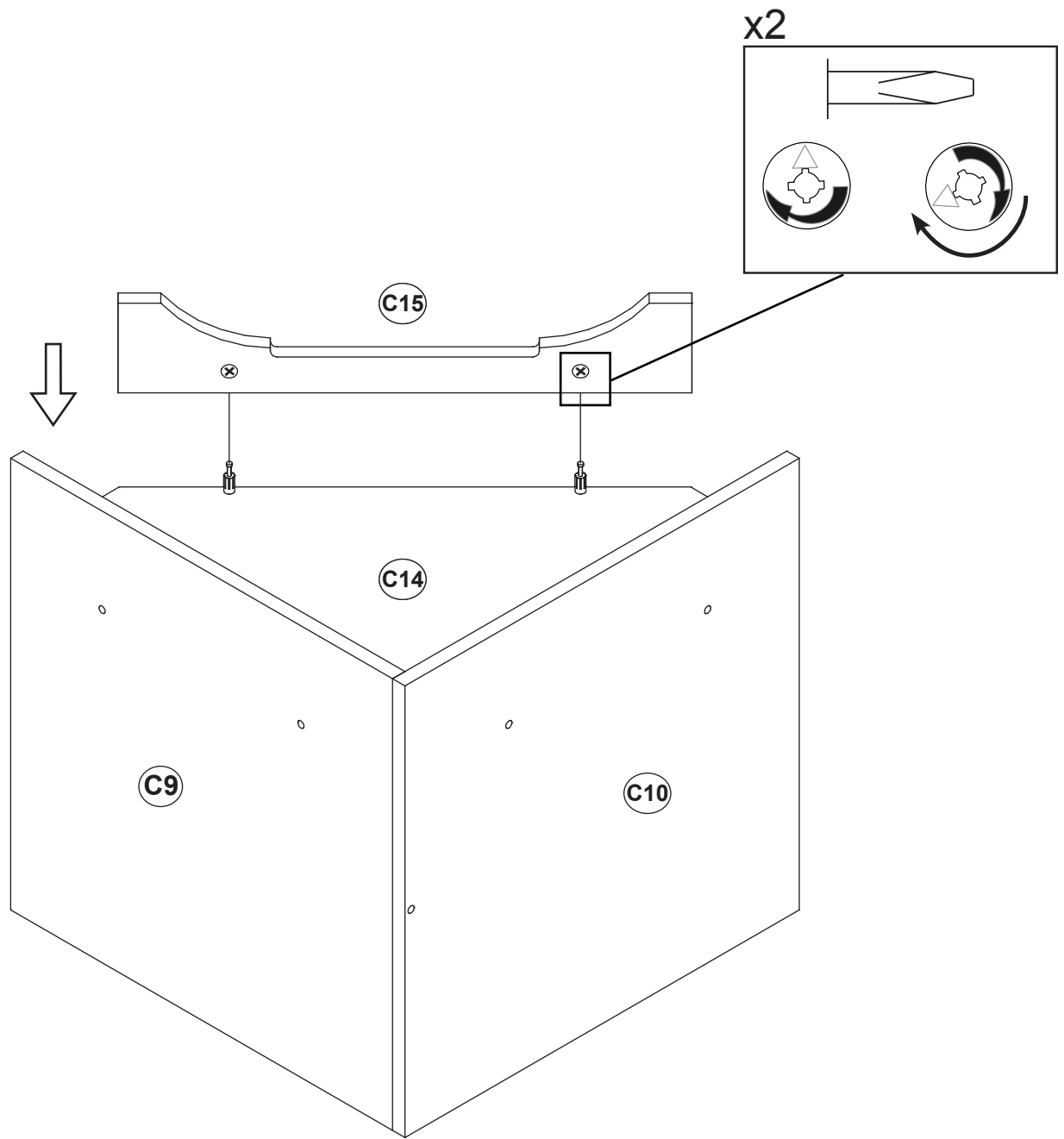

11a

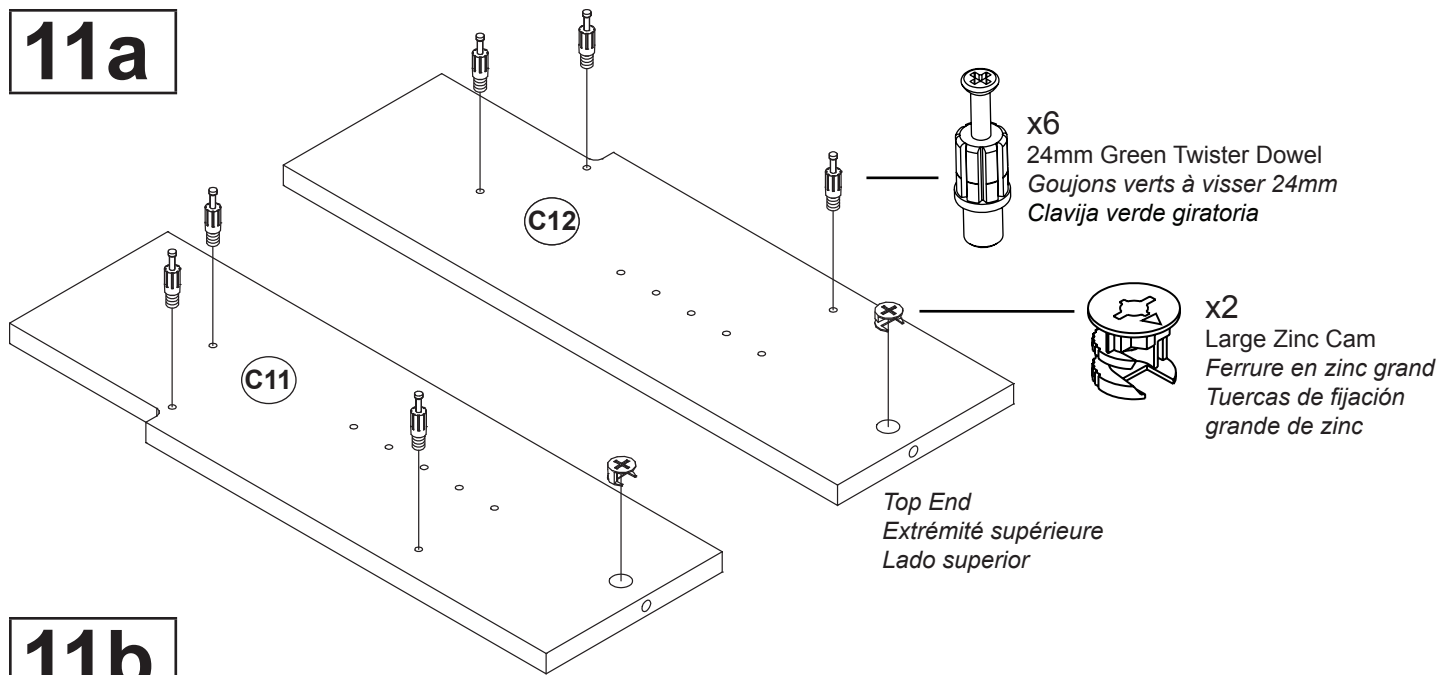

11b

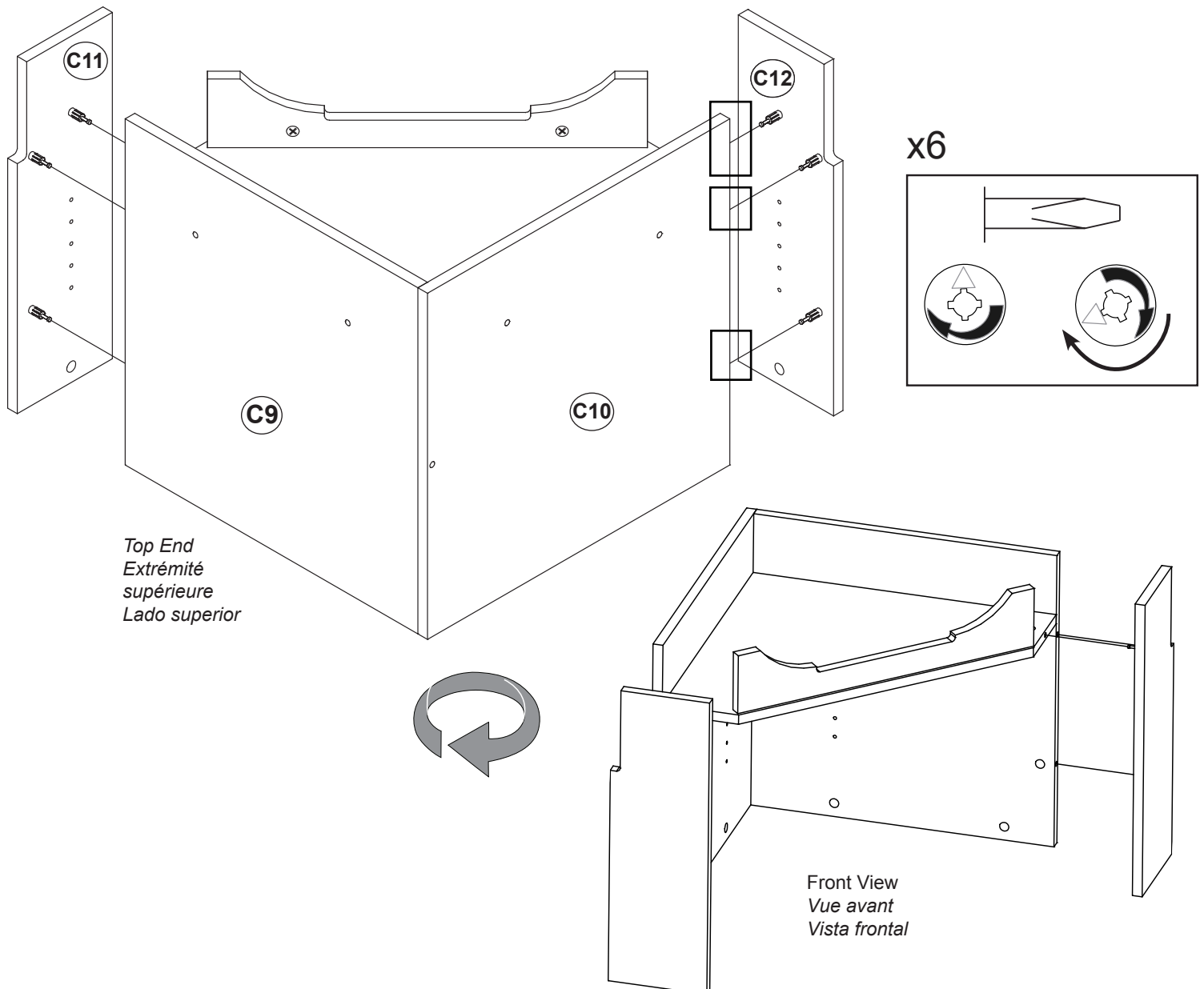

12a

ATTENTION: Make sure to tighten cams before turning over
ATTENTION: Assurez-vous de serrer des ferrures avant le retournement
ATENCIÓN: Asegúrese para apretar discos de leva antes del vuelco

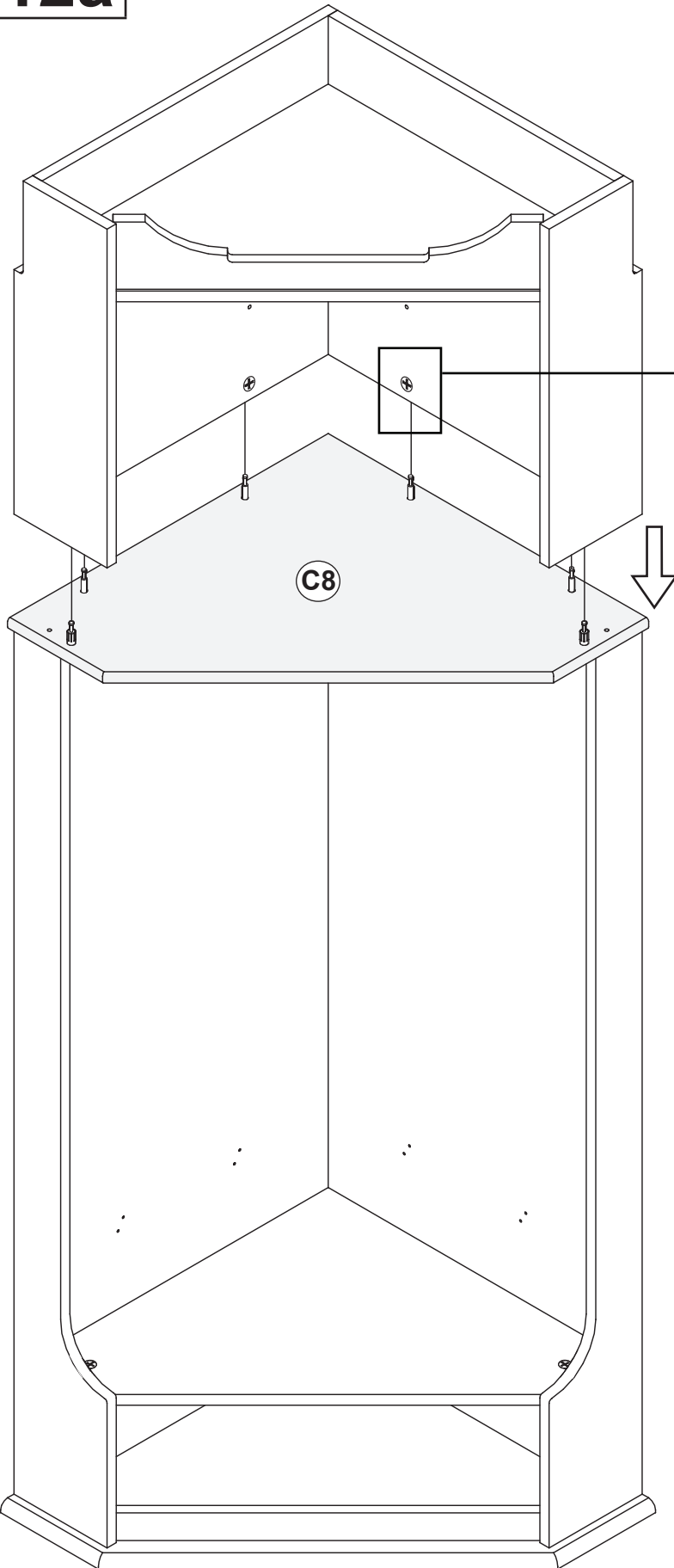

x6

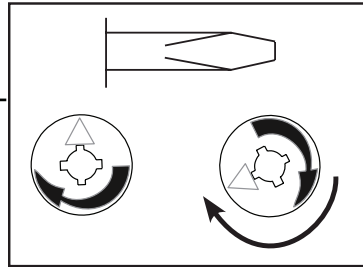

12b

Carefully turn the cabinet over to an upright position
Tourner légèrement le dessus de l'armoire en position verticale
Gire cuidadosamente el gabinete en posición vertical

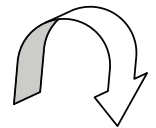

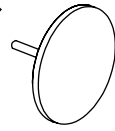
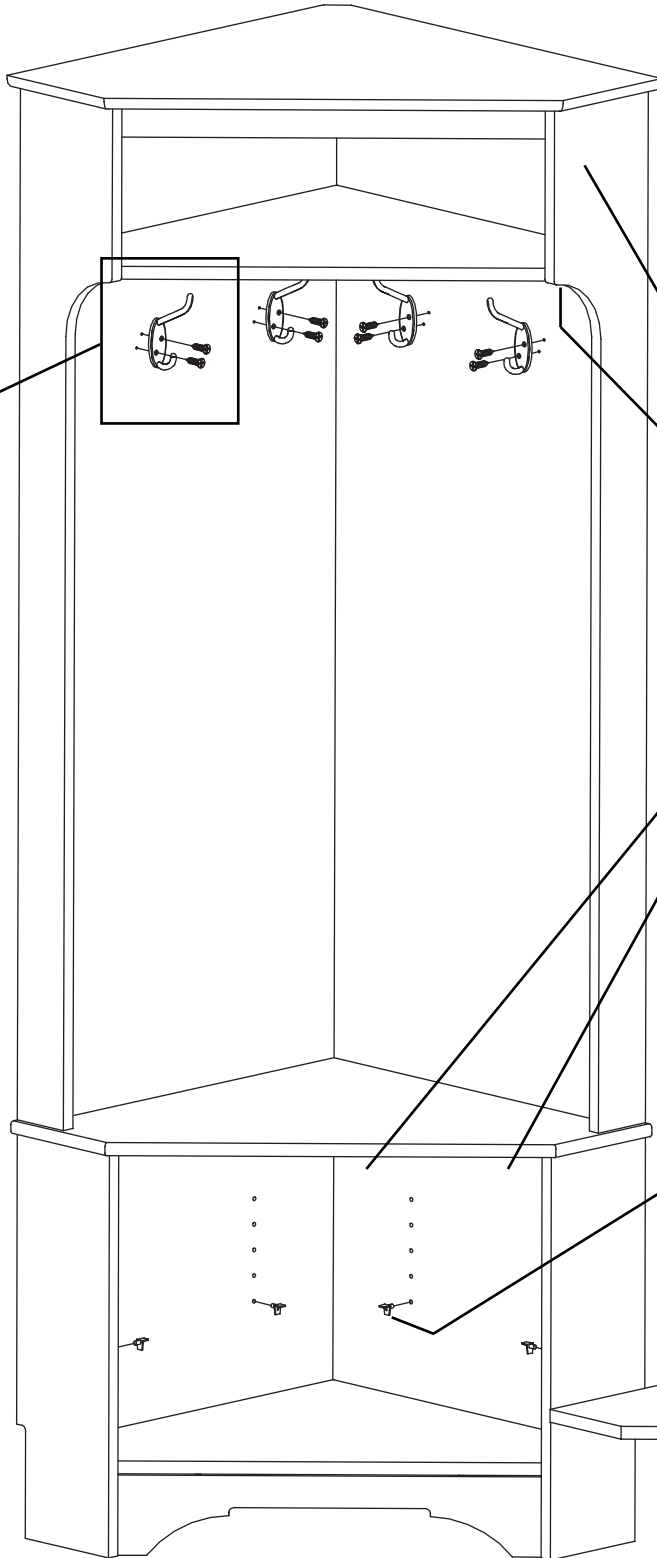
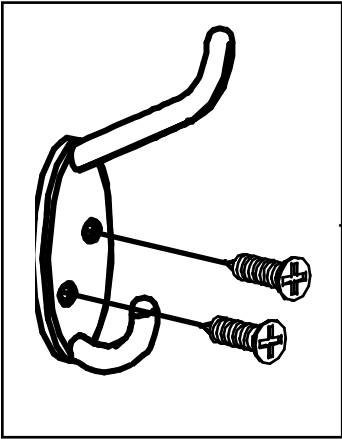

x8
Cam Cover Cap
Capuchons de cames
Cubierta de tuercas



x4
Shelf Support
Support d'étagère
Soporte para estante

14

Attach Safety Bracket to Top of Cabinet and Attach to Wooden Wall Stud
Fixer le support de sécurité vers le haut de l'armoire et le fixer au goujon mural en bois

Fije el soporte de seguridad para la parte superior del armario y fijar a la pared de madera

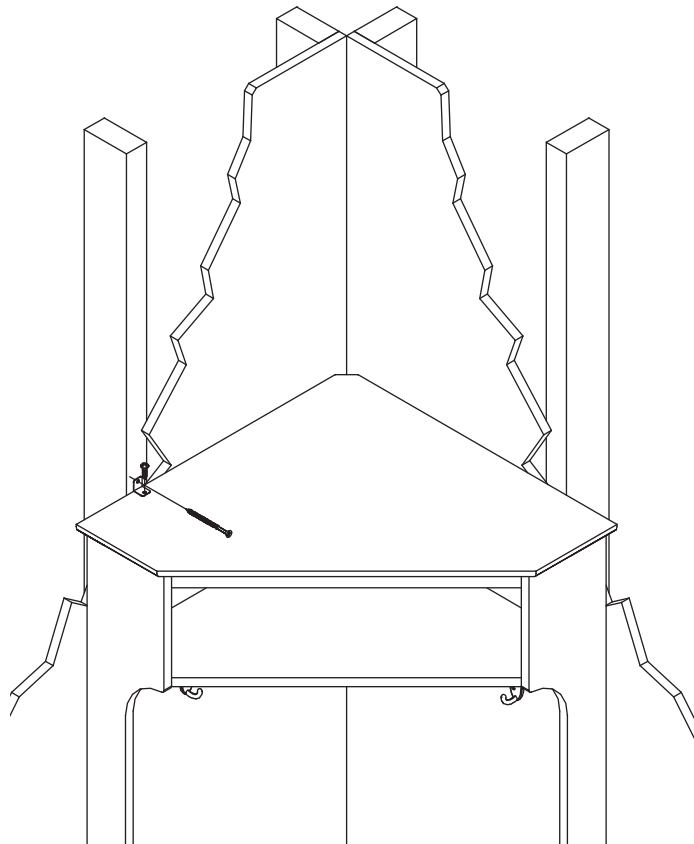
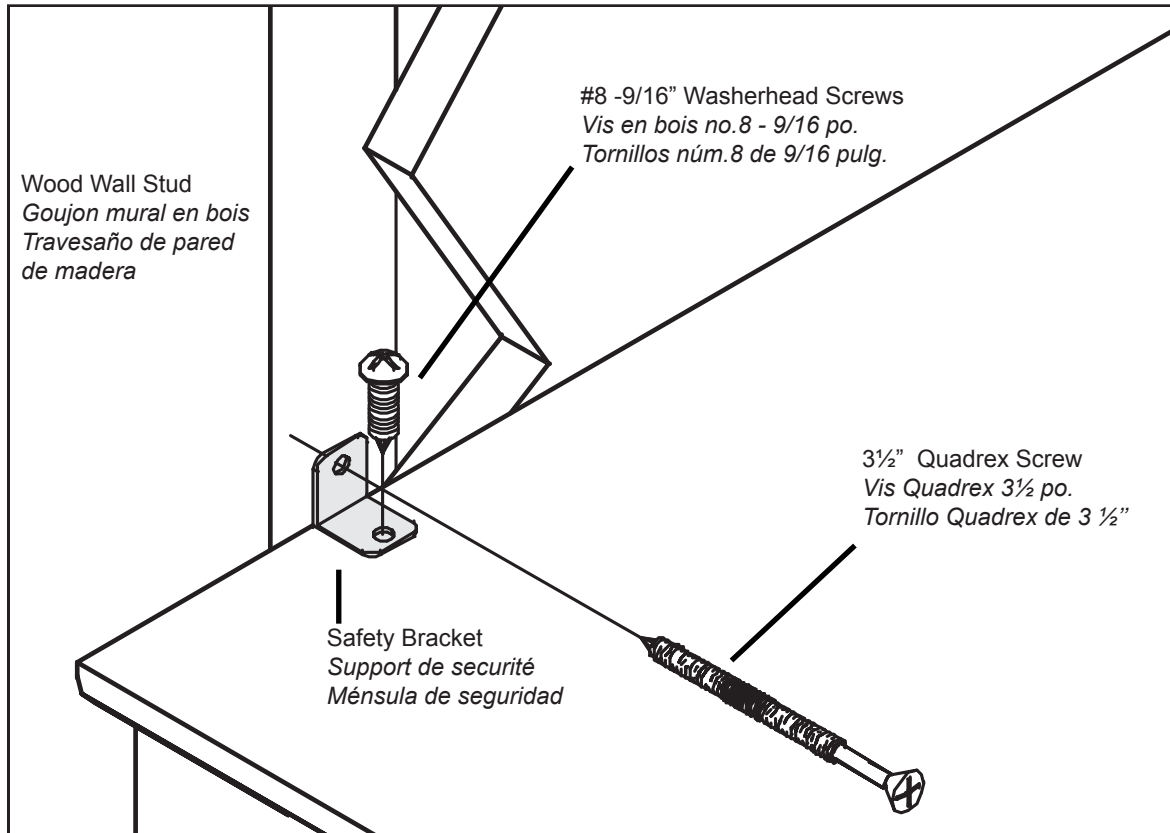

**OR
OU
O**

