



---

## Electronic Dartboard



Please keep this instruction manual for future reference

### Limited 90-Day Triumph Sports USA, Inc. Warranty

If you have any problems with your new product,  
Please contact Triumph Sports USA at 1-866-815-4173,  
or e-mail us at [csr@triumphsportsusa.com](mailto:csr@triumphsportsusa.com)  
for any technical support or warranty issues.

All Triumph Sports USA, Inc. (TSU) games have a limited 90-day from date of purchase warranty. This warrants the retail purchaser for any TSU game purchased to be free from any defect in materials and construction for 90 days from the date of purchase. The only exceptions to the warranty include main frames, tabletops, playing surfaces, batteries or tools. Damaged main frames, tabletops, playing surfaces need to be returned to the store as we are unable to replace these parts. Normal play wear and usage is not covered under the warranty, nor is wear or damage due to improper use of the TSU game. This will void any and all TSU warranties.

**A PURCHASE RECEIPT (or other proof of purchase date) will be required before any warranty service is initiated. All requests for warranty service can be submitted by email, in writing or by contacting our Customer Service Department at:**

**1-866-815-4173 or email us at [csr@triumphsportsusa.com](mailto:csr@triumphsportsusa.com).**

**IMPORTANT NOTICE! Please contact us before returning the product to the store.**

## Warnings



**WARNING:**Choking Hazard--Toy contains small balls and/or small parts.  
Not for children under 3 years of age.



**WARNING:**this is not a child's toy. Adult supervision is required for children playing darts. Proper use of darts can prevent damage or injury.

**Be sure to check out all the exciting games**  **has to offer.**

**Visit our web site at:**

[www.triumphsportsusa.com](http://www.triumphsportsusa.com)



**BILLIARDS**



**DARTS**



**GAME TABLES**



**CASINO**



**OUTDOOR GAMES**



**DARTBOARDS**

Triumph Sports USA  
11327 W Lincoln Ave.

West Allis, WI 53227

[www.triumphsportsusa.com](http://www.triumphsportsusa.com)

©2014 Triumph Sports USA. All Rights Reserved.

## UNPACKING THE GAME

Unpack your new dartboard carefully, making sure all parts are included. The following components are included in this set:

- 1 Electronic Dartboard
- 6 Darts (unassembled)
- Soft tip replacement pack
- Ac Adapter
- Owner's Manual
- Memory Card (Inside dartboard)

## MOUNTING INSTRUCTION

Choose a location to hang the dartboard where there is about 10 feet of open space in front of the board. The "toe-line" should be 7'9 1/4" (2.37 M) from the face of the dartboard for steel tip rules or 8 feet for soft tip rules. You will need to mount the board close to an electric outlet if your dartboard requires an AC adapter. Locate a wall stud and place a mark 76.75" from the floor. Insert a screw in the center of the wall stud at this height and hand the dartboard on this screw.

If not mounting into studs, be sure to use drywall anchors or other securing hardware appropriate to the wall you are using.

If you want to mount the dartboard even more securely to the wall, you can fasten four screws (not included) through the holes located in the catch ring area (the area outside the scoring segments).

This will further secure the board to the wall. Center of bulls eye should be 5' 8" from the ground. Plug the A/C adapter into the wall outlet and into the jack at the button of the dartboard and you're ready to play.

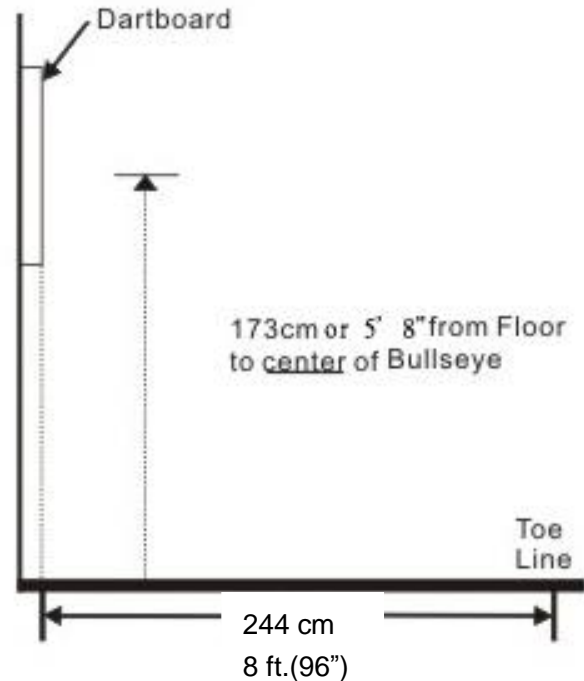

## DARTBOARD FUNCTIONS

**START button** - This multi-function button is used to:

- START:** the game when all options have been selected.
- CHANGE:** to the next player when one player is finished with his round.

This will put dartboard in HOLD status between rounds to allow player to remove darts from the target area.

**DIRECTION buttons** – Press to move the cursor:

**Up button** - go up; Cancel a dart throw during a play;

**Left button**- go left;

**Right button**- go right;

**Down button**- go down;

**BACK button**- Press to go back; Press and hold for 3 second to turn off software;

**POWER SWITCH**- Press to turn off power;

## ELECTRONIC DARTBOARD OPERATION

1. Plug adapter to activate dartboard.
2. Press **UP** and **DOWN** buttons to browse among **GAMES**, **CAREER GAMES**, **PLAYER INFO**, **OPTIONS** and **RATING** and press **START** button to choose the operation.
3. Choose **GAMES** if you want to have a quick game. You can't choose characters and the score will be not recorded to player's history. Press **UP** and **DOWN** buttons to select games and press **START** button to confirm. Choose game variations and press **START** button to go to next step. Press **UP** and **DOWN** buttons to select number of players and press **START** button to confirm. Game start~
4. Choose **CAREER GHAMES** if you wish the playing score to be recorded to player's history. Press **UP** and **DOWN** buttons to browse among 01 Games, Cricket and Count up and press **START** button to choose the desired game. Choose game variations and press **START** button to go to next step. Press **UP** and **DOWN** buttons to select number of players and press **START** button to confirm. Next step is to choose/ set up characters.
5. To set up a character, choose **New Role** and press **START** button. Enter desired name by pressing **UP** and **DOWN** buttons to choose

letters from the alphabet. The limit is 6 letters. Press **LEFT** button if you want to cancel an input. Press **START** button to choose your avatar character.

6. Choose the characters of player 1 and player 2 and press **START** button to enter the game. Game start-
7. At any time, if you want to go back to the menu or last step, press **BACK** button
8. You can see the characters' scoring history in Player Info. Choose **PLAYER INFO**, choose the character and game, you will see the history in 30 rounds.
9. You can set up the custom dartboard settings in **Options** from the menu. Press **DIRECTION** buttons to select and press **START** button to confirm.
  - i. **BRIGHTNESS**: Adjust the brightness of the display
  - ii. **VOLUME**: Adjust the sound volume of the dartboard
  - iii. **I-MATCH**: Adjust the difficulty level of a computer rival
  - iv. **BULL**: Adjust the 50/50 bulls eye or 25/50 for outer/inner bulls eye; the default setting is 50/50
  - v. **CRICKET DISPLAY**: Adjust cricket display style
  - vi. **ROUNDS**: Adjust the game round number; the limit is 30 rounds per game
  - vii. **CHANGE TIME**: Adjust the AUTOMATIC change time between player's turns; choose NONE if you wish to change by manually pressing the button.
  - viii. **DISPLAY COLOR**: choose background color
  - ix. **DEFAULT SETTING**: restore default setting; **CAUTION! ALL PLAYER HISTORY WILL BE ERASED!**
10. Throw darts
  - i. The dart indicator display is represented by dart icons. The number of darts displayed indicates the remaining throws for the active player.
  - ii. When all 3 darts have been thrown, a flashing button will remind you to change player. If you set up **CHANGE TIME option**, the player will change automatically by the set time. Please remove the dart before press START to change player. If there is an inadvertently score, press **UP** button to cancel the score.

## iMATCH FEATURE

This exciting feature allows player to play against the computer at one of five different levels of skill – only 1 player can compete against the iMATCH competitor. This adds a level of competition to normally routine practice sessions.

iMATCH Levels:

- C5 Professional
- C4 Advanced
- C3 Intermediate
- C2 Novice
- C1 Beginner

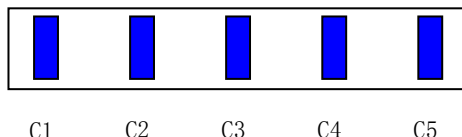

## PLAYING TECHNIQUES

1. Proper stance: Align your hand, elbow, shoulder, hip, and foot. If throwing with your right hand, turn the right side of your body to face the board. Put your weight on your right foot in the front, lean forward slightly, and balance with your left foot. Reverse this stance for a left-handed throw.
2. Throwing motion: Throw the dart from your elbow out. Keep your body steady and use only your hand, wrist, and forearm. Bring your forearm back slightly and throw the dart with a fluid motion toward the board. Follow through the throw by pointing your index finger at the area at which you are aiming.

## GAME RULES

1. Each person should have one set of 3 darts (darts not included). Each person throws 3 darts, and then removes them before the next person throws.
2. If a dart bounces out it cannot be re-thrown. Dart scores are counted only when the dart sticks in the board.

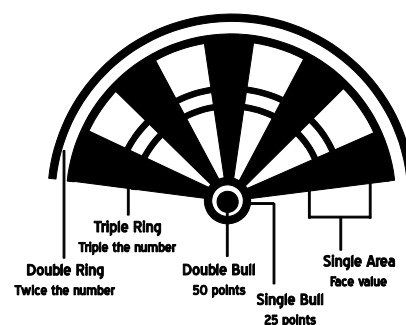

## DISPLAY PROTECTIVE FILM

This electronic dartboard may have a clear film over the entire display area to prevent scratching during shipping. It is recommended that this film be removed before play to enhance the display area visibility. To remove, simply lift edge, peel off, and discard.

## GAMES

### **01 GAMES:** 1-8 players or 1-4 teams

This popular tournament and pub game is played by subtracting each dart from the starting number (301) until the player reaches exactly 0 (zero). If a player goes past zero it is considered a "Bust" and the score returns to where it was at the start of that round. For example, if a player needs a 32 to finish the game and he/she hits a 20, 8, and 10 (totals 38), the score goes back to 32 for the next round. You can set up the starting number from **301** , **501** , **701** , **901** , **1101** , **1301** , **1501**.

Open In: You can score any point value to begin.

Open Out: You can reach "0" by scoring any point value.

Double In: You must score in a double point value to begin.

Double Out: You must reach "0" by scoring in a double point value.

Master Out: You must reach "0" by scoring in a double or triple point value.

When the game ends, the display will show winner's name and PPD. (Points per dart) Press **START** button to see the rating.

### **CRICKET:** 1-8 players or 1-4 teams

Cricket is a strategic game for accomplished players and beginners alike. Players throw for numbers best suited for them and can force opponents to throw for numbers not as suitable for them. The object of Cricket is to "close" all of the appropriate numbers before one's opponent while racking up the highest number of points. Only the numbers 15 through 20 and the inner/outer bull's eye are used. Each player must hit a number 3 times to "open" that segment for scoring. A player is then awarded the number of points of the "open" segment each time he/she throws a dart that lands in that segment, provided their opponent has not closed that segment. Hitting the double ring counts as two hits, and the triple ring counts as 3 hits

Numbers can be opened or closed in any order. A number is "closed" when the other player(s) hit the open segment 3 times. Once a number has been "closed", any player for the remainder of the game can no longer score on it. Winning - The side closing all the numbers first and accumulating the highest point total is the winner. If a player "closes" all numbers first but is behind in points, he/she must continue to score on the "open" numbers. If the player does not make up the point deficit before the opposing player(s) "closes" all the numbers, the opposing side wins. Play continues until all segments are closed - the winner is the player with the highest score.

**NO-SCORE CRICKET:** Same rules as standard Cricket except there is no point scoring. The object of this version is to be the first to simply "close" all the appropriate numbers (15 through 20 and the bulls eye).

**CUT THROAT CRICKET:** Same basic rules as standard Cricket except once scoring begins, points are added to your opponent(s) total. The object of this game is to end up with the fewest points. This variation of Cricket offers a different psychology to the players. Rather than adding to your own score and helping your own cause as in standard Cricket, Cut-Throat offers the benefit of racking up points for your opponent(s), digging him in a deeper hole. Competitive players will love this variation!

### **COUNT UP:** 1-8 players or 1-4 teams

The object of this game is to score the highest point in 8 rounds. Doubles and triples count 2 or 3 times the numerical value of each segment. The highest score player is the winner..

**COUNT UP 200, 400, 600, 800, 1000:** The object of this game is to be the first player to reach the specified point total.

**CRICKET COUNT UP:** Player can only use the numbers 15 through 20 and the inner/outer bulls eye to score high.

### **OVER:** 1-8 players or 1-4 teams

The object of this game is to simply score higher ("over") or equal than your previous three dart total score. When a player fails to score "over" his/her previous three dart total, he/she will lose one 'life'. The number next to the player indicates remaining 'lives'. The last player with a 'life'

remaining is the winner.

**UNDERS:** This game is the opposite of "Overs". Players must score less ("Under") or equal than their previous three dart total to avoid losing a 'life'.

**BIG SIX:** Single 6 is the first target to shoot for at the start of the game. Within the three throws, player 1 must hit a 6 to "save" their life. After the current target is hit, the next dart thrown will determine the opponent's target. If player 1 fails to hit the current target within 3 darts, they will lose a 'life' and a chance to determine the next target for player 2. In this case, player 2 shoots for the single 6 – and if it is hit, he can throw for a segment for the next round. Singles, doubles and triples are all separate targets for this game. The object of the game is to force your opponent into losing 'lives' by selecting difficult targets for your opponent to hit such as "Double Bulls eye" or "triple 20". The last player with a 'life' left is the winner.

**ROUND THE CLOCK:** 1-8 players or 1-4 teams

Each player attempts to score in each number from 1 through 20 in order. If a correct number is hit, he/she tries for the next number in sequence. The display will indicate which segment you are shooting for. The first player to reach 20 is the winner.

**HIT-OUT:** In each round, the computer selects a target the player must hit. The player must try to hit the target within 10 seconds to score a point. Double and Triple segments are deemed as single segments in this game. The first player who scores 15 points is the winner.

**SHANGHAI:** In 21 rounds, each player must progress around the board from 1 through 20 and bulls eye in order. Players start at number 1 and throw 3 darts. The object is to score the most points possible in each round of 3 darts. Doubles and triples count toward your score. The player with the highest score after completing 21 rounds is the winner.

**HALF-IT:** Each player starts the game with 20 points. The object is to score as many hits in the active segment of the current round. The first round, the player must throw for the 15 segment. If no 15's are hit, player's score is cut in half. If some 15's are hit, each 15 (doubles and triples count) is added to the starting total. The next round players throw for the 16 segment and hits are added to the new cumulative point total. Again, if no hits are registered, the point total is cut in half. Each player throws for the numbers as indicated in the chart below in order (the screen will indicate the active segment in which to throw). The player who completes the game with the most points is the winner

	15	16	D	17	18	T	19	20	B	TOTAL
Player 1										
Player 2			↑			↑				

Any Double

Any Triple

**EXERCISE:** 1 player only

This is a practice game for 1 player only. Game will end at 30 rounds.

### CARING FOR YOUR ELECTRONIC DARTBOARD

- Never use metal tipped darts on this dartboard. Metal tipped darts will seriously damage the circuitry and electronic operation of this dartboard.
- Do not use excessive force when throwing darts. Throwing darts too hard will cause frequent tip breakage and cause excess wear on the board.
- Turn darts clockwise as you pull them from the board. This makes it easier to remove darts and extends the life of the tips.
- Unplug the adapter when not in use. This will prolong the life of your dartboard.
- Clean your dartboard with dry cloth. Do not spill liquids on the dartboard. Do not use spray cleaners, or cleaners that contain ammonia or other harsh chemicals as they may cause permanent damage and are not covered by the warranty.
- Securely mount the dartboard. Falling from the height will damage the display.

### IMPORTANT NOTES

- Stuck Segment: Occasionally, a dart will cause a segment to become wedged within the segment separator web. To free the segment,

simply remove the dart or broken tip from the segment. If the problem is still not solved, try wiggling the segment until it is loose. The game will then resume where it left off.

2. Broken Tips: From time to time a tip will break off and become stuck in the segment. Try to remove it with a pair of pliers or tweezers by grasping the exposed end and pulling it out of the segment. If this is not possible, you can attempt to push the tip through to the back of the segment. Use a nail that is smaller than the hole and gently push the tip until it falls through the other side. Be careful not to push too far and damage the circuitry behind the segment. Don't be alarmed if tips break. This is a normal occurrence when playing soft tip darts. We include a pack of replacement tips that should keep you supplied for quite some time. When replacing tips, make sure you use the same type of tips that come with this dartboard.

## Firmware Update

Download new software from [www.smartdartboard.com](http://www.smartdartboard.com). Unzip the file to a location you can access later.

SD card is located at bottom of the dartboard next to DC jack. Lightly press the SD to eject the SD card.

Install the SD card to a SD card reader and connect it to the computer.

Open the SD card and delete the file in it.

Copy the new software file to the SD card. Once the copy finishes, safely remove the SD card from card reader.

Install the SD card back into to the dartboard. The side with the pin should face the same direction as the dartboard face. If the SD card is in the wrong direction, it can't be installed into the dartboard.

## Dart Ranking System – MPR and PPD

There are 3 Career Games for you to choose to play where statistics can be recorded. They are Cricket, 01 and Count Up and player profiles can be created and you can track your ongoing playing performance. The dartboard is able to keep track of your win and loss record and determine how good of a cricket player you are compared to how well you play at 01 games and Count Up. For Cricket games, player ratings will be determined by the **MPR** (Marks Per Round)

In Cricket, the MPR is calculated by dividing the total number of "marks" scored by the actual number of darts thrown and then multiply by 3. A "MARK" is defined as a "scoring" dart in the game of cricket. An example of "5 marks" would be a triple 15 and a double 16 scored. The cumulative Marks per round average will be the criteria for your Skill level rating as a cricket player.

For "01" and Count up games, players will be ranked by measuring their **PPD** (Points per Dart) The PPD is determined by dividing the total points by the number of actual darts thrown. The player that "wins" the game uses the total points needed to win (i.e. 301,501 etc.) and the losing players calculation is based on what they scored.

The dartboard will automatically calculate your MPR and PPD in **CAREER GAMES** mode and keep a cumulative average.

## Scoring History

To view player's cumulative scoring history and statistics, go to the **PLAYER INFO** option of the dartboard menu and select the players name and game that you wish to view history on. The total will be summarized on the bottom of the screen

## Rating System Chart

The rating chart system shows how you stack up as a cricket player and an "01" player. The rating chart is listed in the instruction manual and can also be viewed on the dartboard by going to **RATING** in the dartboard menu. Rating of 1 is the lowest skill level with 18 being the highest. The PPD and MPR averages required to maintain for all skill levels is listed.

## PLAYER RATING CHART

01 GAME/SCORE GAMES STATS		CRICKET GAMES STATS	
PPD (point per dart)	RATING	MPR (Mark per Round)	RATING
0~13.32	1	0~1.29	1
13.33~14.99	2	1.30~1.49	2
15.00~16.66	3	1.50~1.69	3
16.67~18.32	4	1.70~1.89	4
18.33~19.99	5	1.90~2.09	5
20.00~21.66	6	2.10~2.29	6
21.67~23.32	7	2.30~2.49	7
23.33~24.99	8	2.50~2.69	8
25.00~26.66	9	2.70~2.89	9
26.67~28.32	10	2.90~3.09	10
28.33~29.99	11	3.10~3.29	11
30.00~31.66	12	3.30~3.49	12
31.67~33.32	13	3.50~3.69	13
33.33~34.99	14	3.70~3.89	14
35.00~36.66	15	3.90~4.09	15
36.67~38.32	16	4.10~4.29	16
38.33~39.99	17	4.30~4.49	17
40-	18	4.5-	18

## Replacement Parts

Description	Model	Price
<b>Ac Adapter (USB Jack)</b>	<b>ADAPTERTFT</b>	<b>\$12.95</b>
<b>6 Replacement Soft tip Darts</b>	<b>SFT6DARTS</b>	<b>\$12.95</b>
<b>7"Replacement Screen Shield</b>	<b>SCREENSHIELD</b>	<b>\$12.95</b>
<b>Control Panel</b>	<b>PD100 Panel</b>	<b>\$12.95</b>