



ITEM# WN500MB
 Winston Panel Mounting Bracket
 26"x4 3/4"x57"H

Your furniture purchase is an investment. Here are a few tips to maximize the lifetime of your furniture with a minimal amount of effort. Properly caring for your furniture can help ensure that it looks great year after year.

Wood Furniture Maintenance:

- Always dust, wipe, and clean with the grain of the wood.
- Dust with a soft cloth. Dust will scratch the furniture surface if not removed properly.
- If a polished surface becomes foggy, rub it with a cloth dipped in a solution of one tablespoon vinegar to one quart of water. Rub softly with the grain until the surface is completely dry.
- Soap and water are not advisable for wood surfaces. Water can penetrate the finish and raise the grain on wood, causing damage.
- Remember to change dusting cloths frequently as dirty cloths may scratch your furniture's surface.

The Enemies of Wood:

- Moisture is wood's worst enemy. Liquid spills should be gently wiped up immediately. Coasters should be used under all beverages.
- Do not allow rubber or vinyl materials to lie on the furniture. Chemicals in rubber may leave a stain. Put a strip of felt or leather under accessories that have rubber or vinyl.
- Heat creates a chemical change in the furniture's finish, which result in a white spot. Use protective pads under hot dishes, appliances, etc.
- Sunlight's ultraviolet rays can damage the finish of furniture. DO not place furniture directly against a heater or radiator and do not place in the path of hot streams of air from central heating. This will cause extreme localized drying of the wood.

Marble Top Maintenance:

The surface of the marble on your table has been polished and sealed to create a generally non-porous surface. The stone has many natural characteristics including veining, hairline cracks, and color variations, which make up the stone's beauty.

To maintain the beauty of your marble:

- Protect surfaces from scratching, staining and etching by:
 - Keeping them free of debris or sharp objects.
 - Wiping up spills immediately
 - Avoiding contact with chemicals (particularly acid-based materials)
- Clean with PH neutral products or those especially formulated for use on stone.
- It is not recommended to use a water-based solvent for dark marble as it will remove the polish from the surface.

Caring for the Fabric on Upholstered Furniture:

- Frequent vacuuming of the entire upholstered area will prevent dust from settling into the fibers.
- Professional cleaning is always recommended for all upholstered pieces.
- Do not use cleaning products containing brightening agents.

VERY IMPORTANT!!			
<p>NEVER USE GLASS CLEANERS ON FINISHED SURFACES. AMMONIA WILL CHEMICALLY ATTACK THE FINISH.</p>	<p>DO NOT WRITE DIRECTLY ON SURFACE </p> <p>PREVENT MARKING</p>	<p>DO NOT PLACE IN DIRECT SUNLIGHT </p> <p>PREVENT FADING</p>	<p>DO NOT USE RUBBER- BASED FLACEMATS USE CLOTHS! </p> <p>PREVENT DISCOLORING</p>
<p>NEVER ALLOW LIQUIDS OF ANY KIND TO LINGER ON SURFACES ABSORPTION CAUSES THE WOOD TO WARP AND THE FINISH TO DE-LANINATE</p>	<p>DO NOT USE COMMERCIAL WAXES AND POLISHES </p> <p>PREVENT YELLOWING</p>	<p>DO NOT PLACE HOT KETTLES POTS, ETC ON SURFACE </p> <p>PREVENT DAMAGE TO FINISH</p>	<p>MAINTAIN EVEN HUMIDITY CONDITIONS IN YOUR HOME </p> <p>PREVENT SPLITTING</p>

WN500MB

Assembly Instruction

* Do not tighten screws & bolts until the entire item is completely assembled.

Step 1

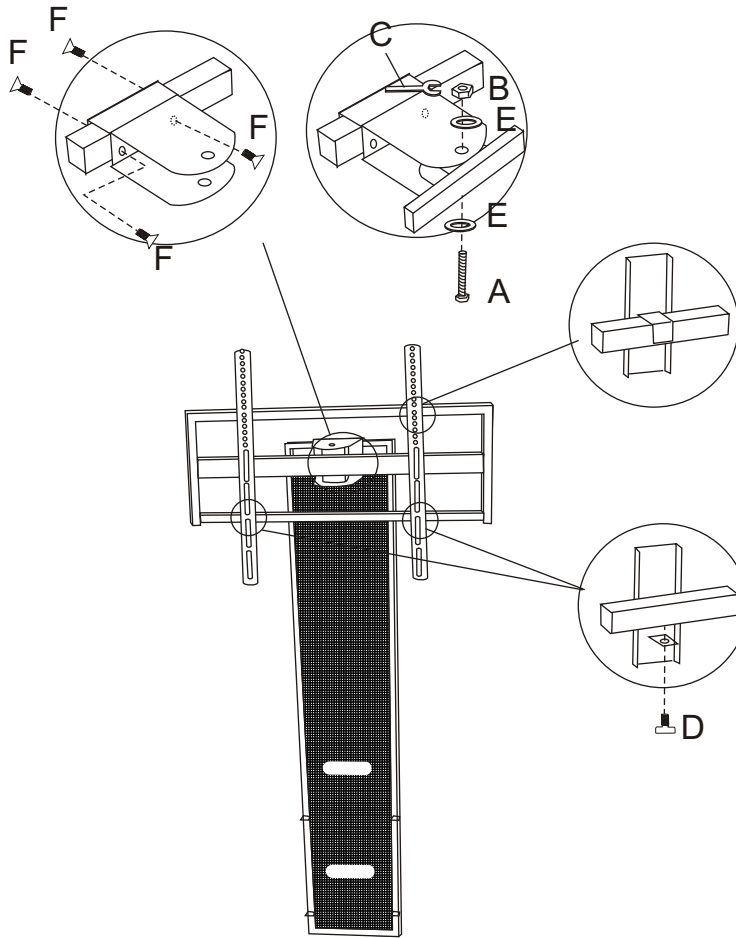

Step 2

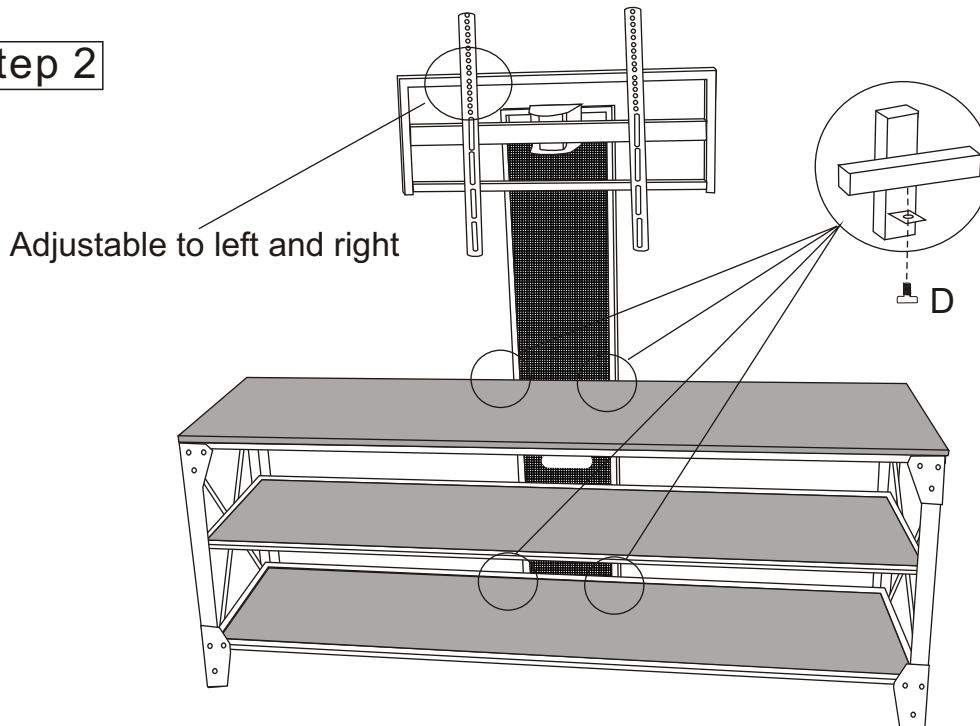

Hardware Pack #: PWN500MBH

A		1PC	$\Phi 10 * 110\text{mm}$
B		1PC	$\Phi 10 * \Phi 16\text{mm}$
C		1PC	16mm
D		6PCS	1/4" X 15mm
E		2PCS	$\Phi 12 * 16\text{mm}$
F		4PCS	1/4" X 15mm

Parts for WN500MB

Complete Hardware#: PWN500MBH

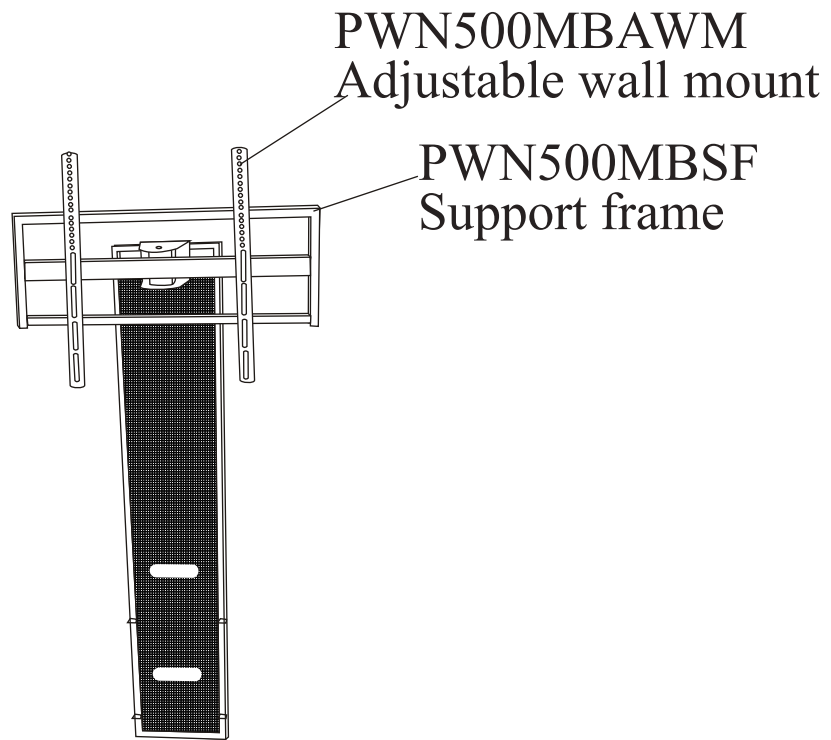

PRODUCT DETAILS	
MATERIAL	IRON
METAL COLOR	ANTIQUÉ FINISH
PRODUCT SIZE	MB: 26" X 4 3/4" X 57"
CARTON SIZE	MB: 50 3/5" X 10 1/4" X 3 2/3"
NET WEIGHT	MB: 19. 1LBS
GROSS WEIGHT	MB: 20. 8LBS
CU.FT.	MB: 1. 11'

MADE IN CHINA