



Princess Toddler Bed

Assembly Instructions

If you are without an instruction sheet,
DO NOT use this product.
Call 1-800-933-0771 or fax 1-877-933-0771.

© 2009 KidKraft, LP

The mattress intended for use on the bed shall be a full-size crib mattress having minimum dimensions of 51 5/8 in. (1310 mm) in length, and 27 1/4 in. (690 mm) in width and 4 in. (100 mm) in thickness.
DO NOT USE FOR INFANTS. The toddler bed is intended for a child over 15 months old and less than 50 lbs. (22.7kg).
Before assembly, inspect toddler bed for damaged hardware, loose joints, missing pieces or sharp edges.
DO NOT use bed if any parts are missing or damaged. Do not substitute parts.

Item #76121

Please retain this information for future reference

To order replacement parts, please visit www.kidkraft.com

HARDWARE:

A. Pink Cross Dowel Bolt x 18 pcs



(2 7/16in, 62mm)

B. Pink Cross Dowel Bolt x 2 pcs



(2 in, 51mm)

C. Cross Dowel Bolt x 8 pcs



(1 1/4in, 32mm)

D. Cross Dowel Nut x 18 pcs



E. Nylon Lock Nut x 10 pcs



F. Pink Cross Dowel Bolt x 8 pcs



(1 3/16in, 30mm)

G. Washer x 10 pcs



H. Screw x 4 pcs



(7/8in, 20 mm)

Wrench x 1 pc



Allen Wrench x 1 pc



The following tool (not included) is required for assembly:



Flathead screwdriver

PARTS LIST:

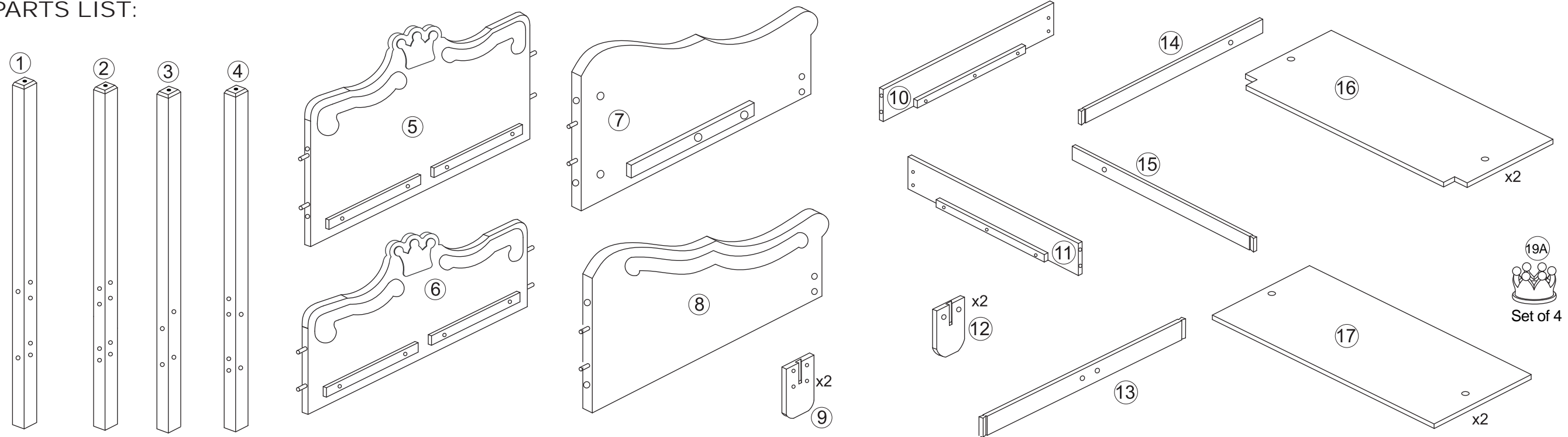

Step 1

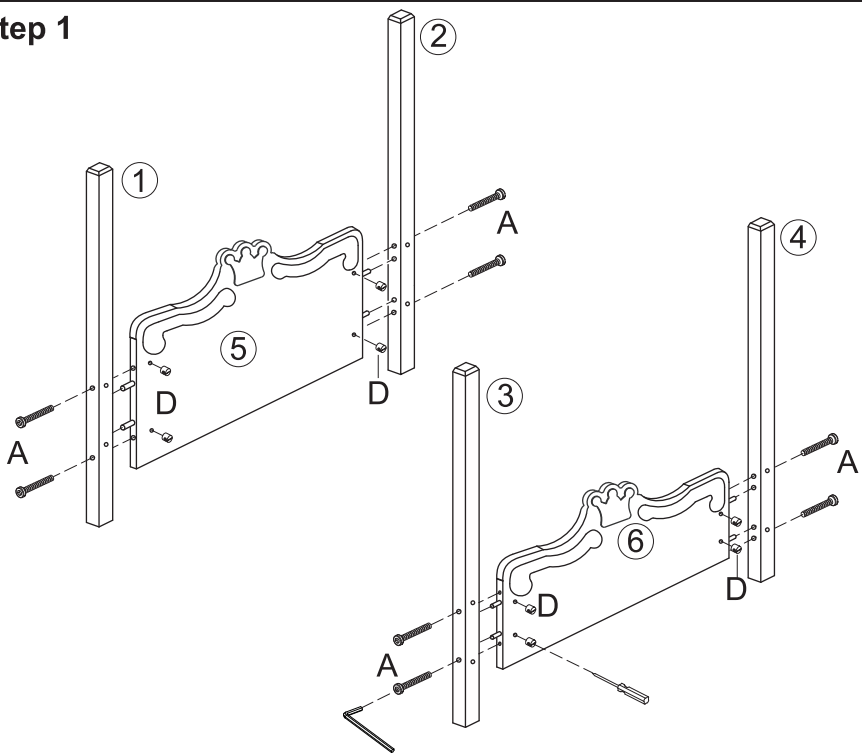

Step 2

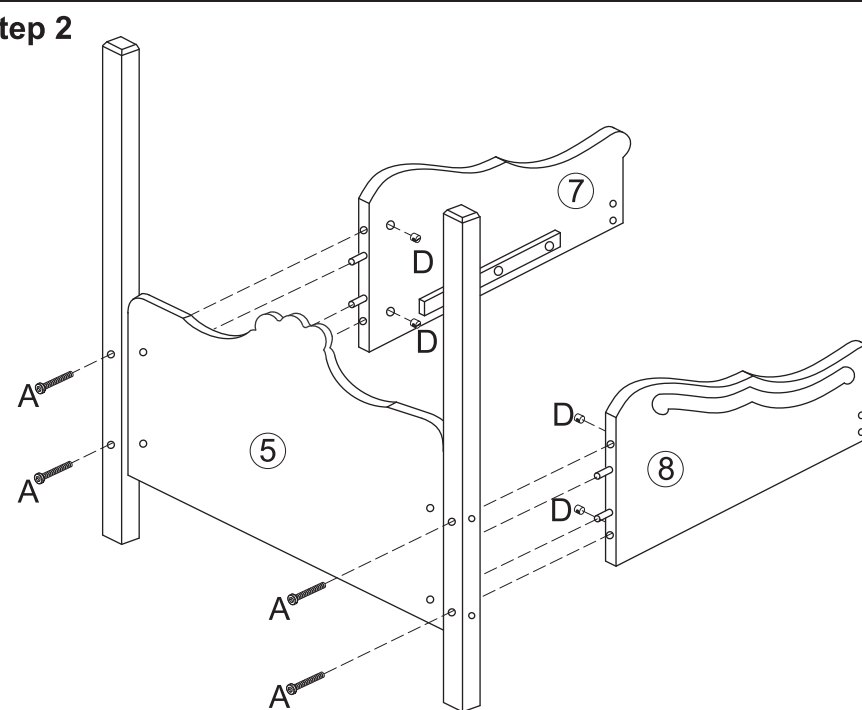

Step 3

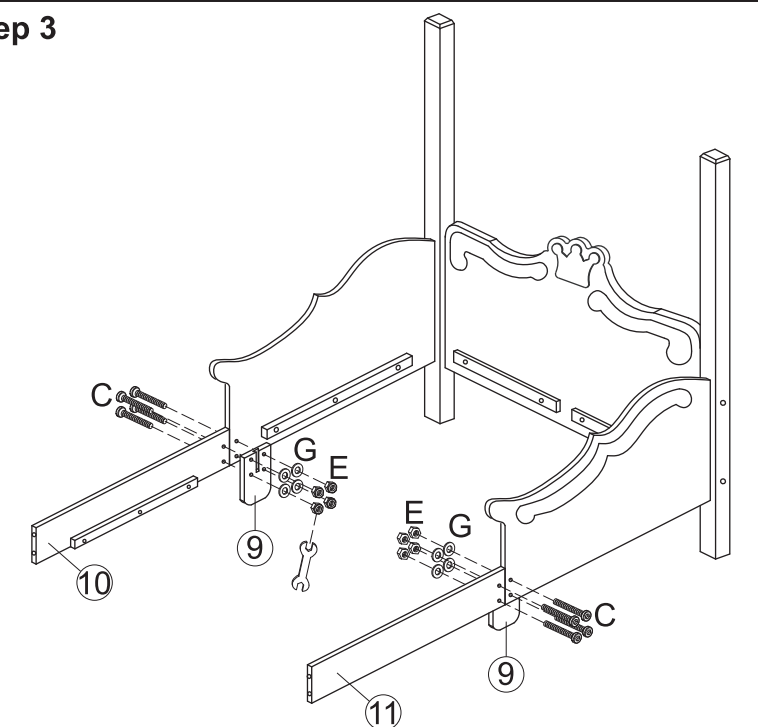

WARNING:
ADULT ASSEMBLY REQUIRED.
Product includes small parts with potentially hazardous sharp points and sharp edges in the unassembled state. Keep unassembled parts away from children.

WARNING:
CHOKING HAZARD. Small parts and sharp points, not suitable for children under 3 years.

USE AND MAINTENANCE:

-Use on level surfaces only
-Please check assembly at regular intervals, and frequently tighten hardware if necessary. If maintenance is not carried out, the product could cease to function properly.

WARNING:

ENTRAPMENT/STRANGULATION HAZARD
Infants have died in toddler beds from entrapment and strangulation. Failure to follow these warnings and the assembly instructions could result in serious injury or death.

DO NOT place bed near windows where cords from blinds or drapes may strangle a child.

DO NOT place items with a string, cord, or ribbon around a child's neck, such as hood strings or pacifier cords.
DO NOT suspend strings over a toddler bed for any reason.

Customer Service
1-800-933-0771
www.kidkraft.com



© 2009 KidKraft, LP

Princess Toddler Bed

Assembly Instructions

The mattress intended for use on the bed shall be a full-size crib mattress having minimum dimensions of 51 5/8 in. (1310 mm) in length, and 27 1/4 in. (690 mm) in width and 4 in. (100 mm) in thickness.
DO NOT USE FOR INFANTS. The toddler bed is intended for a child over 15 months old and less than 50 lbs. (22.7kg).
Before assembly, inspect toddler bed for damaged hardware, loose joints, missing pieces or sharp edges.
DO NOT use bed if any parts are missing or damaged. Do not substitute parts.

If you are without an instruction sheet,
DO NOT use this product.
Call 1-800-933-0771 or fax 1-877-933-0771.

Item #76121

To order replacement parts, please visit www.kidkraft.com

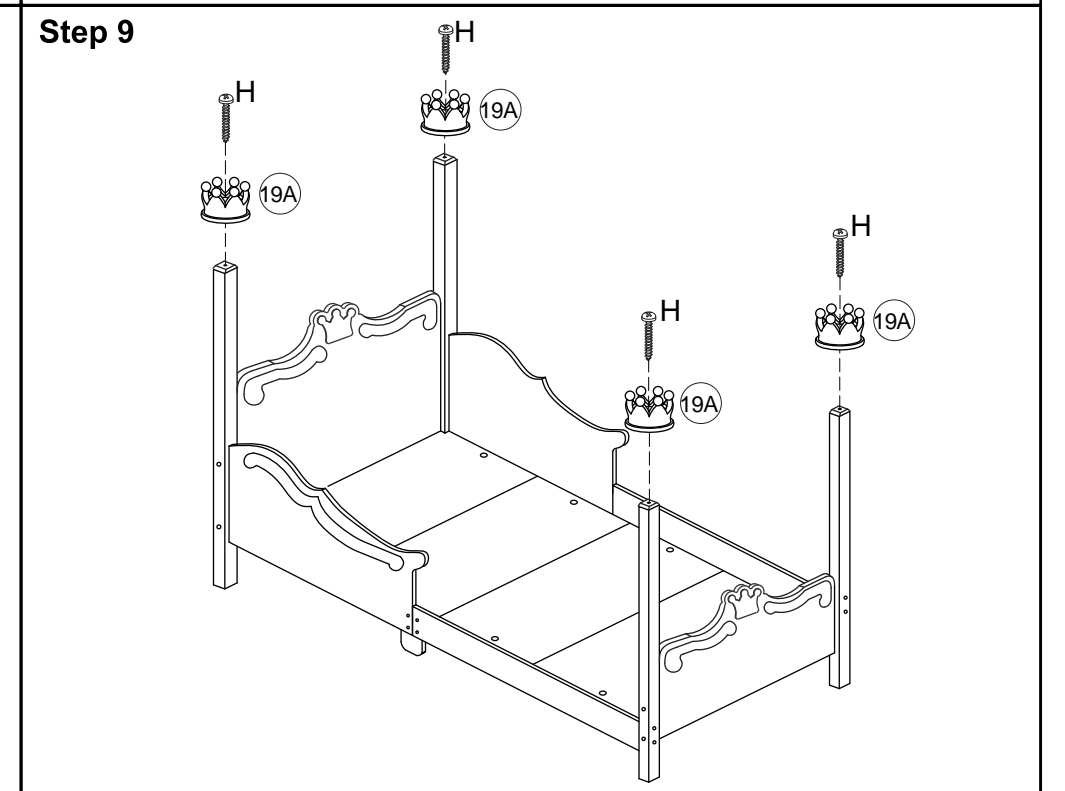
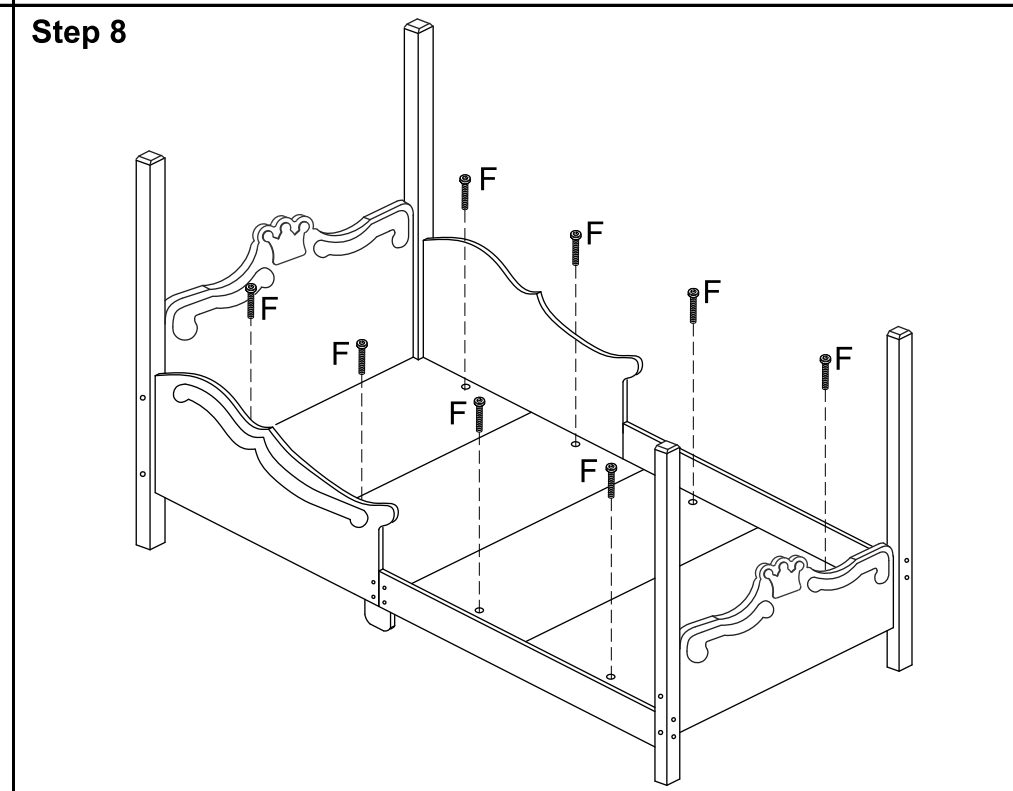
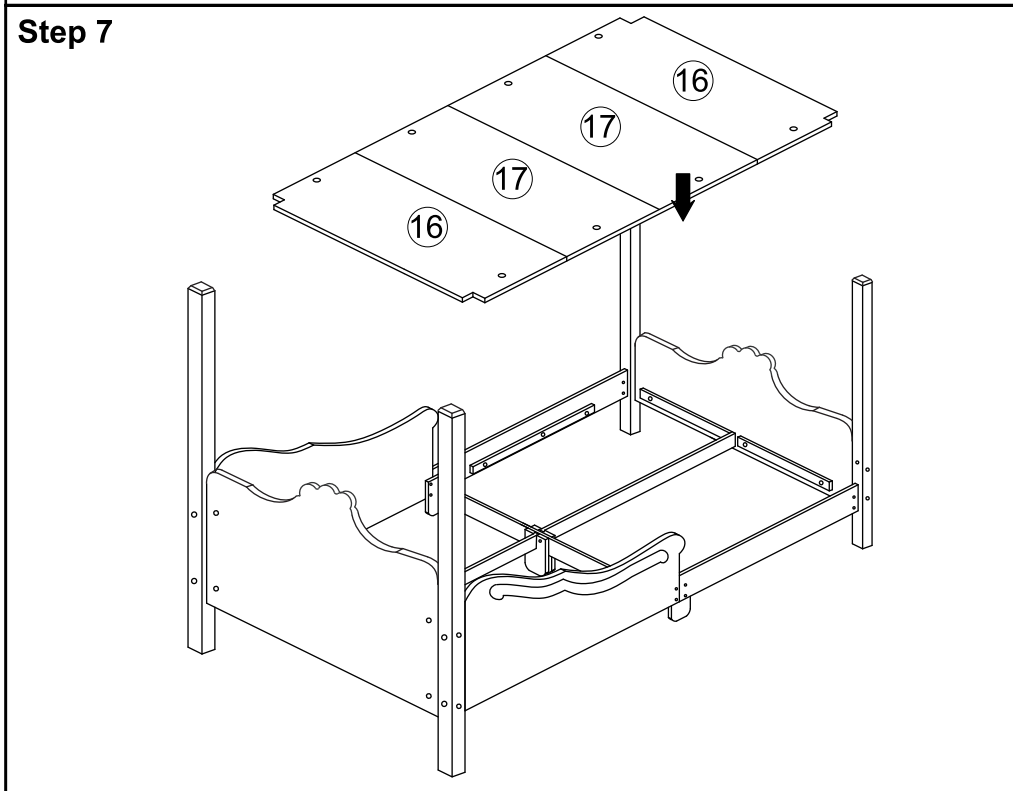
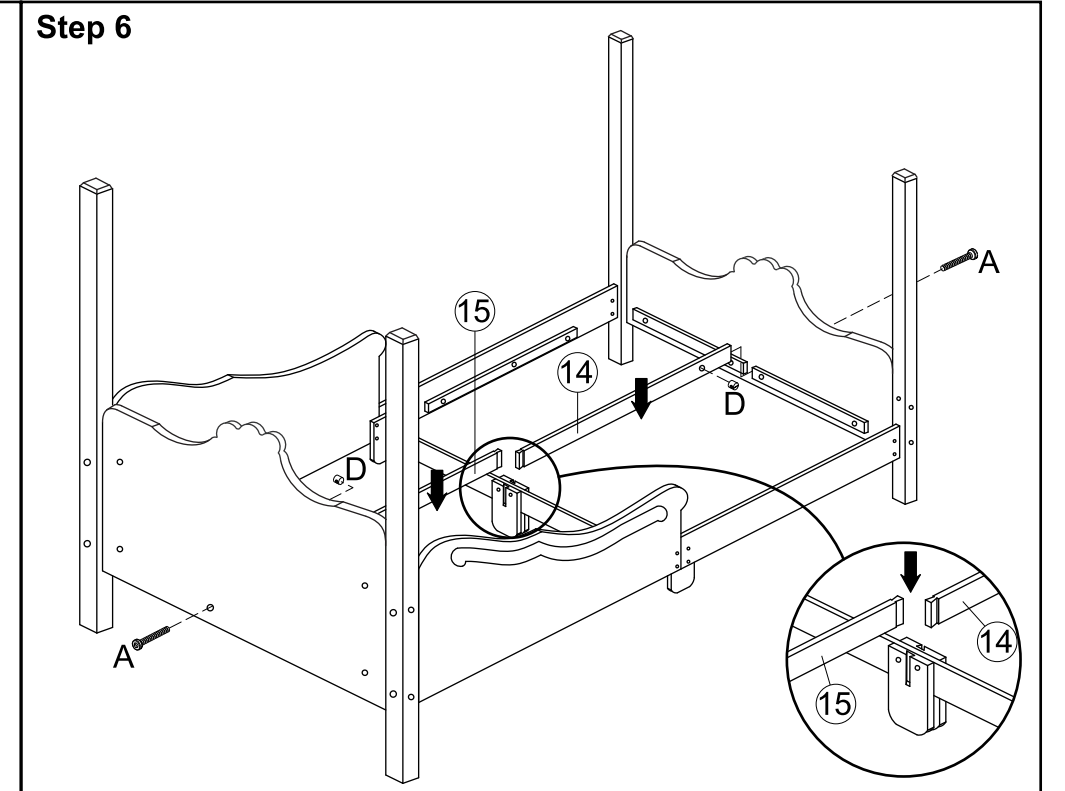
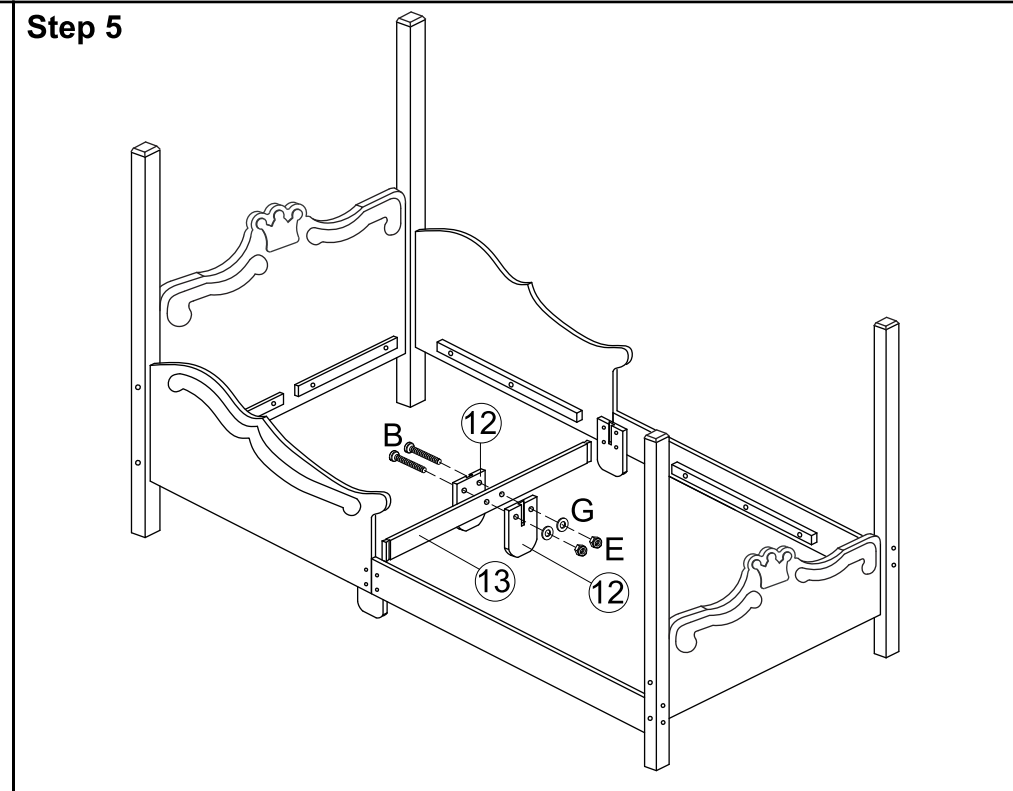
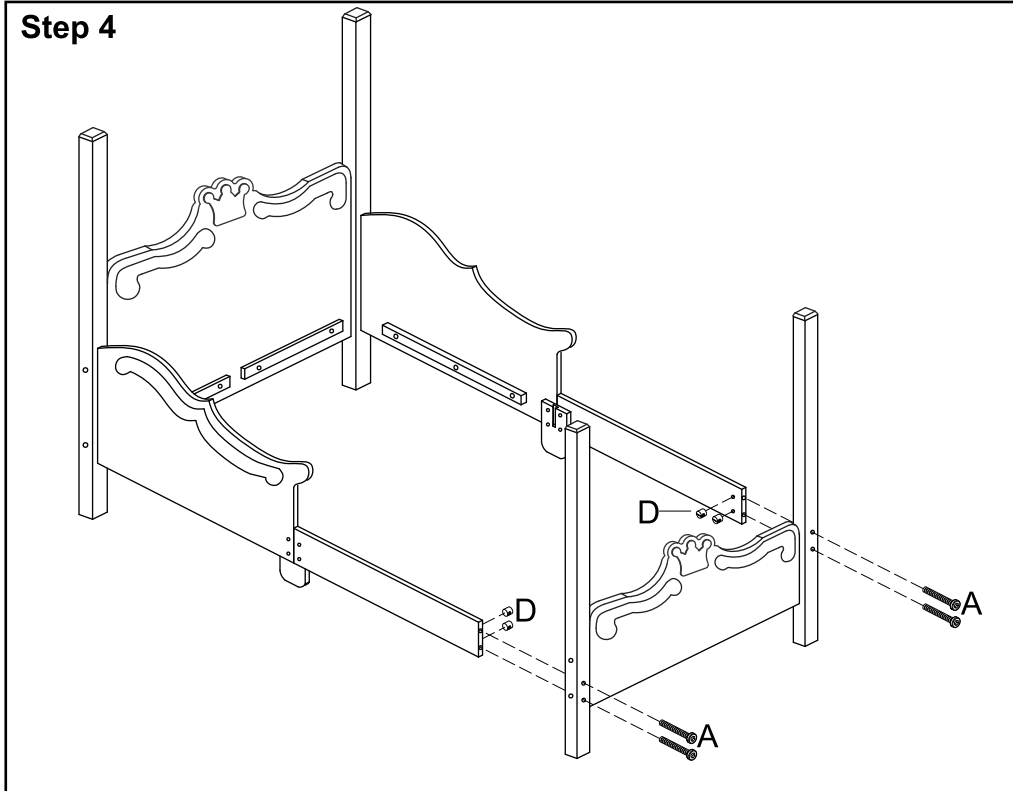

Before calling customer service, please locate the batch code number (example: 105906/65006/04) found on the bottom or back of your product.

Customer Service
1-800-933-0771
www.kidkraft.com



Warning: This is intended for children of a specific age or above. Keep children younger than the specified age from using this item. Do not let children of any age climb on or around this item. Adult supervision is always recommended.

IMPORTANT INFORMATION - PLEASE READ FIRST

ALL OF OUR WOODEN ITEMS ARE HANDCRAFTED, HAND ASSEMBLED, AND HAND PAINTED. EACH ONE IS UNIQUE. SLIGHT IMPERFECTIONS MAY OCCUR AND ARE NOT MANUFACTURING DEFECTS.

PLEASE NOTE THAT WE DO NOT WARRANTY AGAINST THE USE OF PERMANENT MARKERS, NON-WATER-BASED PAINTS, CRAYONS, OR WASHABLE MARKERS. SOME OF THESE ITEMS CONTAIN PERMANENT COLOR DYES THAT COULD DAMAGE THE SURFACE.

CLEANING INSTRUCTIONS

CLEAN THE SURFACE USING A SLIGHTLY DAMP CLOTH AND MILD DISH WASHING LIQUID IF NECESSARY. DO NOT USE ANY CLEANING PRODUCT CONTAINING ALCOHOL OR AMMONIA. THESE WILL DULL THE SHINY SURFACE OF THE PRODUCT. FURNITURE POLISH WILL ALSO WORK TO CLEAN AND DUST OFF THE SURFACE.

WE RECOMMEND THAT YOU TEST ALL CLEANING MATERIALS ON THE UNDERSIDE OF ANY SURFACE THAT WOULD NOT BE SEEN DURING NORMAL USE OF THE PRODUCT. IF YOU HAVE QUESTIONS REGARDING THE MAINTENANCE OF THIS PRODUCT PLEASE FEEL FREE TO CALL US.

SOLE AND LIMITED WARRANTY

THIS PRODUCT IS WARRANTED SOLELY AGAINST MANUFACTURING DEFECTS FOR A PERIOD OF 90 DAYS FROM THE DATE OF PURCHASE, WHICH RUNS ONLY TO THE ORIGINAL USER OF THE PRODUCT. IN THE EVENT OF A MANUFACTURING DEFECT, PARTS WILL BE REPLACED OR THE ENTIRE PRODUCT WILL BE REPLACED OR THE PURCHASE PRICE WILL BE REFUNDED, AT THE ELECTION OF THE MANUFACTURER. TO ACTIVATE AND PROTECT THIS WARRANTY, PRESERVE EVIDENCE OF ORIGINAL PURCHASE AND CAREFULLY INSPECT THE CONDITION OF THE PRODUCT PRIOR TO AND AFTER ASSEMBLY, LOOKING FOR MISSING, DEGRADED, BROKEN, IMPROPERLY SIZED OR HAZARDOUS PARTS, INCLUDING PARTS WHICH CAN BE SWALLOWED BY A CHILD, CAUSE A CHILD TO CHOKE, OR OTHERWISE CAUSE INJURY. SUCH PARTS MAY INCLUDE LOOSE SCREWS, EXPOSED NAILS OR SHARP EDGES. SHOULD YOU OBSERVE ANY DEFECTS, DO NOT USE THE PRODUCT AND IMMEDIATELY NOTIFY THE MANUFACTURER. FAILURE TO DO SO SHALL CONSTITUTE MISUSE. MISUSE, IMPROPER ASSEMBLY, FAILURE TO HONOR A WARNING, FAILURE TO SUPERVISE, INSPECT OR MAINTAIN THE PRODUCT, OR DAMAGE TO THE PRODUCT, WHETHER INTENTIONAL OR INADVERTENT, SHALL INVALIDATE THIS WARRANTY. THIS WARRANTY GIVES YOU SPECIFIC LEGAL RIGHTS, AND YOU MAY ALSO HAVE OTHER RIGHTS WHICH VARY FROM STATE TO STATE.

TO SUBMIT A WARRANTY CLAIM PLEASE CONTACT KIDKRAFT CUSTOMER SERVICE AT 1-800-933-0771 FOR INSTRUCTIONS ON HOW TO PROVIDE PROOF OF PURCHASE AND HOW TO RETURN THE ITEM FREIGHT PRE-PAID.

CUSTOMER SERVICE 1-800-933-0771

www.kidkraft.com