

**Model # DC-6330**

DATE STAMP	
------------	--

**CALL US FIRST**  
**1-877-PREPAC1**  
**1-877-773-7221**



Mon - Fri 7am - 4pm PST  
 10am - 7pm EST

- For help with assembly
- If you have received a damaged or defective part or are missing hardware.

We will process replacement parts in 2 business days or less. Parts are shipped via UPS Ground or mail.

**Before you call please:**

- 1) Record the following information from the shipping label on the outside of the box. You will need it for warranty purposes:
  - Ship To Name
  - Sales Order Number
- 2) Note the product model number.
- 3) Review the contents of your shipment to determine what you are missing.

**Online Option:**

Fill out the Replacement Parts Order form in the Product Support section of our website: [www.prepacmfg.com](http://www.prepacmfg.com)

## 6-Drawer Dresser Assembly Instructions

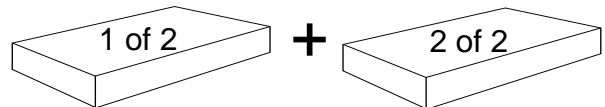

This product is shipped in  
**2 cartons**



Make sure you have both cartons. Sometimes cartons shipped on the same day get separated and are delivered on different days.

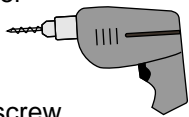

Depending on collection, the style of your product may vary from this picture.

Required Tools	Optional Tools
<p>Screwdrivers</p>  <p>Phillips Head</p>  <p>Flat Head</p>  <p>Hammer</p>	<p>Using a power screwdriver will speed up assembly.</p>  <p><b>Caution</b>                      Do not over tighten any screw. The last few turns of each screw should be done very slowly or by hand.</p>

Prepac Manufacturing Ltd.  
 6705 Dennett Place  
 Delta, BC V4G 1N4

LB-0595-R  
 2012-06-15

# Hardware Identification

## Cabinet Hardware

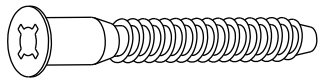

2" Confirmat Screws  
(8)  
**RM-0001**



Screw Cover Caps  
(8)  
**RM-0226** black  
**RM-0620** cherry  
**RM-0304** espresso  
**RM-0523** maple  
**RM-0008** white

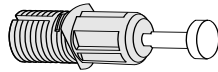

Blue Rapid Rod  
(2)  
**RM-0583**

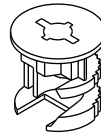

15mm Zinc Cam  
(8)  
**RM-0103**

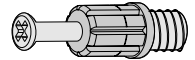

Green Twister Dowel  
(6)  
**RM-0501**

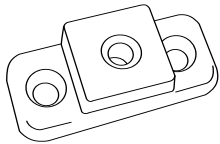

T Spacer  
(24)  
**RM-0628**

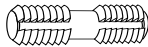

Plastic Dowels  
(14)  
**RM-0072**



3/4" Nail  
(36)\*  
**RM-0022**



Drawer Slide Screw  
(72)  
**RM-0074**

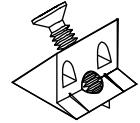

Drawer Bottom Stabilizer  
(6)  
**RM-0839**

\*More than required

\*More than required

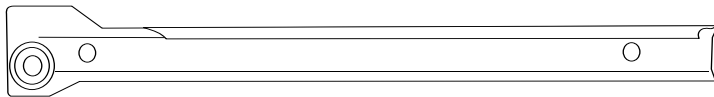

**LEFT Cabinet Slide (6)**

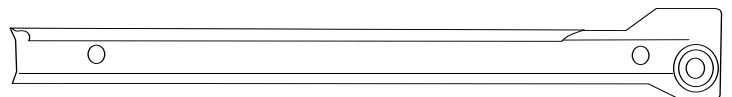

**RIGHT Cabinet Slide (6)**

## Drawer Hardware

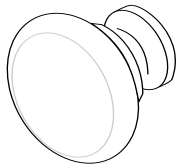

Knob (12)  
**RM-0464** maple / black  
**RM-0625** white / cherry  
**RM-0464E** espresso



#8 7/8" Machine Screw  
(12)  
**RM-0465**

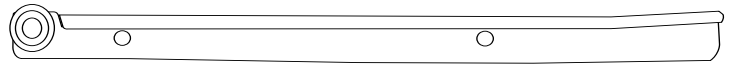

**1 LEFT Drawer Slide per Drawer (Total = 6)**

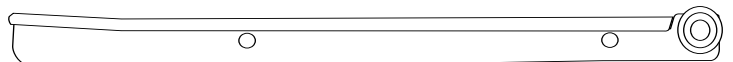

**1 RIGHT Drawer Slide per Drawer (Total = 6)**

**Set of Grey Drawer & Cabinet Slides (6 Sets)  
RM-0469-G**

4 per drawer



#8 - 1 1/2" Hi Lo Screws  
(24)  
**RM-0504**



12mm Zinc Cam  
(24)  
**RM-0715**

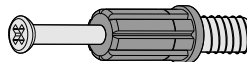

Black Twister Dowel  
(24)  
**RM-0500**

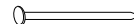

3/4" Nail  
(24)  
**RM-0022**



Drawer Slide Screw  
(24)  
**RM-0074**

## Cable Tie Hardware Package

HP-0608

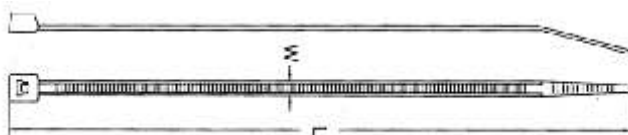

Cable Tie (1)  
*Attache pour câble*  
**RM-0459**



Mounting Base (2)  
*Base de support*  
**RM-0458**

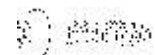

#6-3/4" Pan Head  
Screw (1)  
*Vis #6-3/4 po.*  
**RM-0460**

# Cabinet Parts

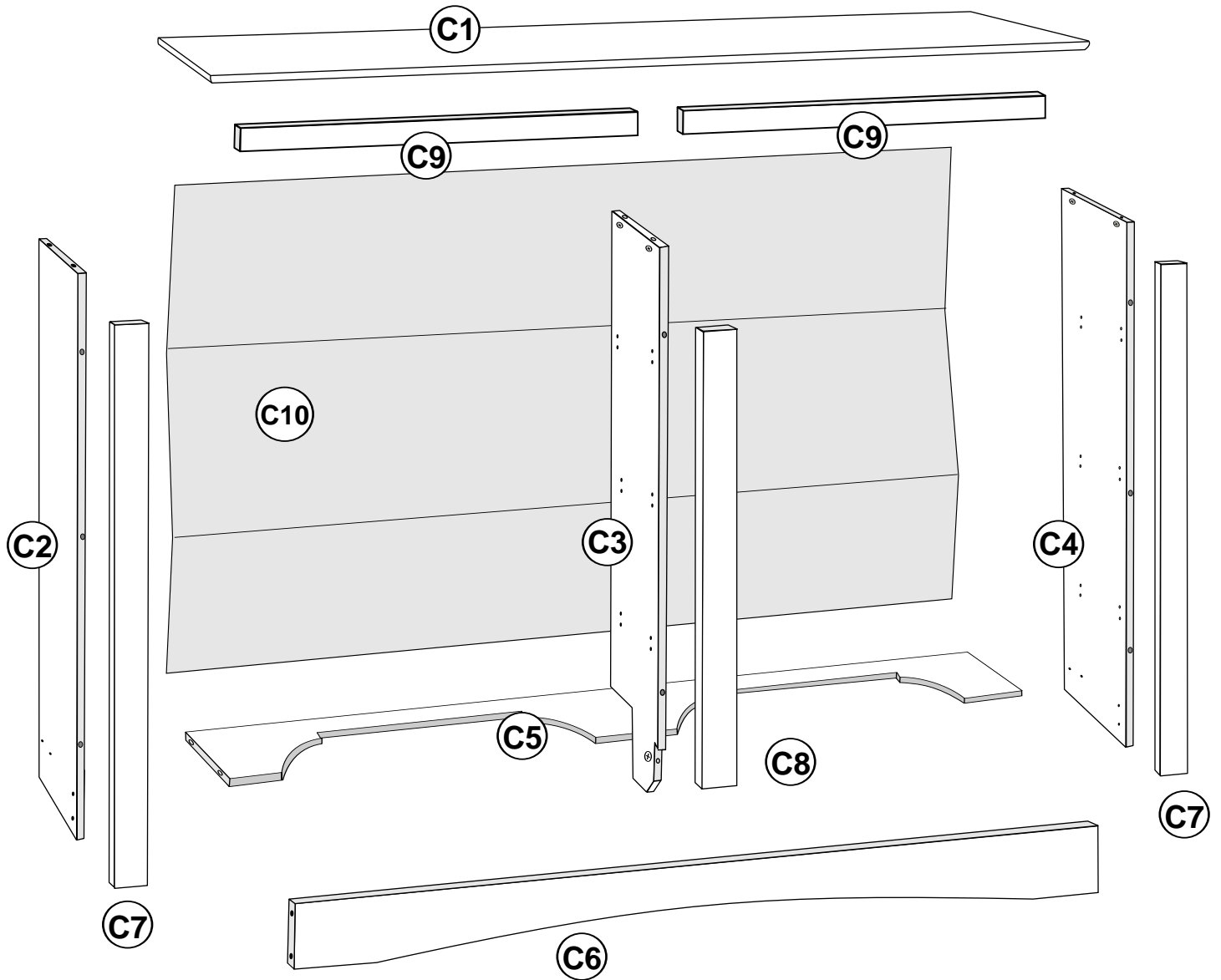

**C1**

Profiled Top (1)  
**TP-0413** black  
**TP-0493** cherry  
**TP-0463** espresso  
**TP-0473** maple  
**TP-0403** white

**C2**

Left Side (1)  
**SL-4110** black  
**SL-4910** cherry  
**SL-4610** espresso  
**SL-4710** maple  
**SL-4010** white

**C3**

Center Divider (1)  
**GA-4110** unfinished

**C4**

Right Side (1)  
**SR-4110** black  
**SR-4910** cherry  
**SR-4610** espresso  
**SR-4710** maple  
**SR-4010** white

**C5**

Decorative Stabilizer A (1)  
**ST-4114** black  
**ST-4914** cherry  
**ST-4614** espresso  
**ST-4714** maple  
**ST-4014** white

**C6**

Decorative Stabilizer B (1)  
**KR-0413** black  
**KR-0493** cherry  
**KR-0463** espresso  
**KR-0473** maple  
**KR-0403** white

**C7**

1 3/4" Side Molding (2)  
**TR-4116** black  
**TR-4916** cherry  
**TR-4616** espresso  
**TR-4716** maple  
**TR-4016** white

**C8**

1 3/4" Center Molding (1)  
**TR-0415** black  
**TR-0495** cherry  
**TR-0465** espresso  
**TR-0475** maple  
**TR-0405** white

**C9**

1 3/4" Top Molding (2)  
**TR-4112** black  
**TR-4912** cherry  
**TR-4612** espresso  
**TR-4712** maple  
**TR-4012** white

**C10**

Folded Backer (1)  
**BB-0107**

**STEP 1 Estimated Time: 15 - 25 minutes**

**1a** Attach T-spacers to left and right sides and to both sides of the center divider using drawer slide screws

**1b** Then, attach metal cabinet slides to T-spacers using drawer slide screws

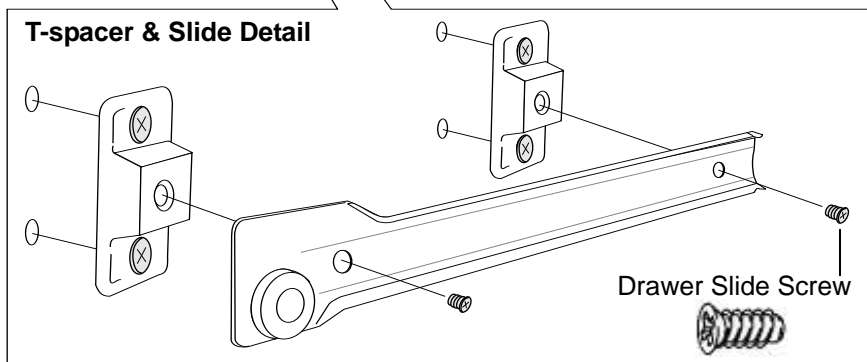
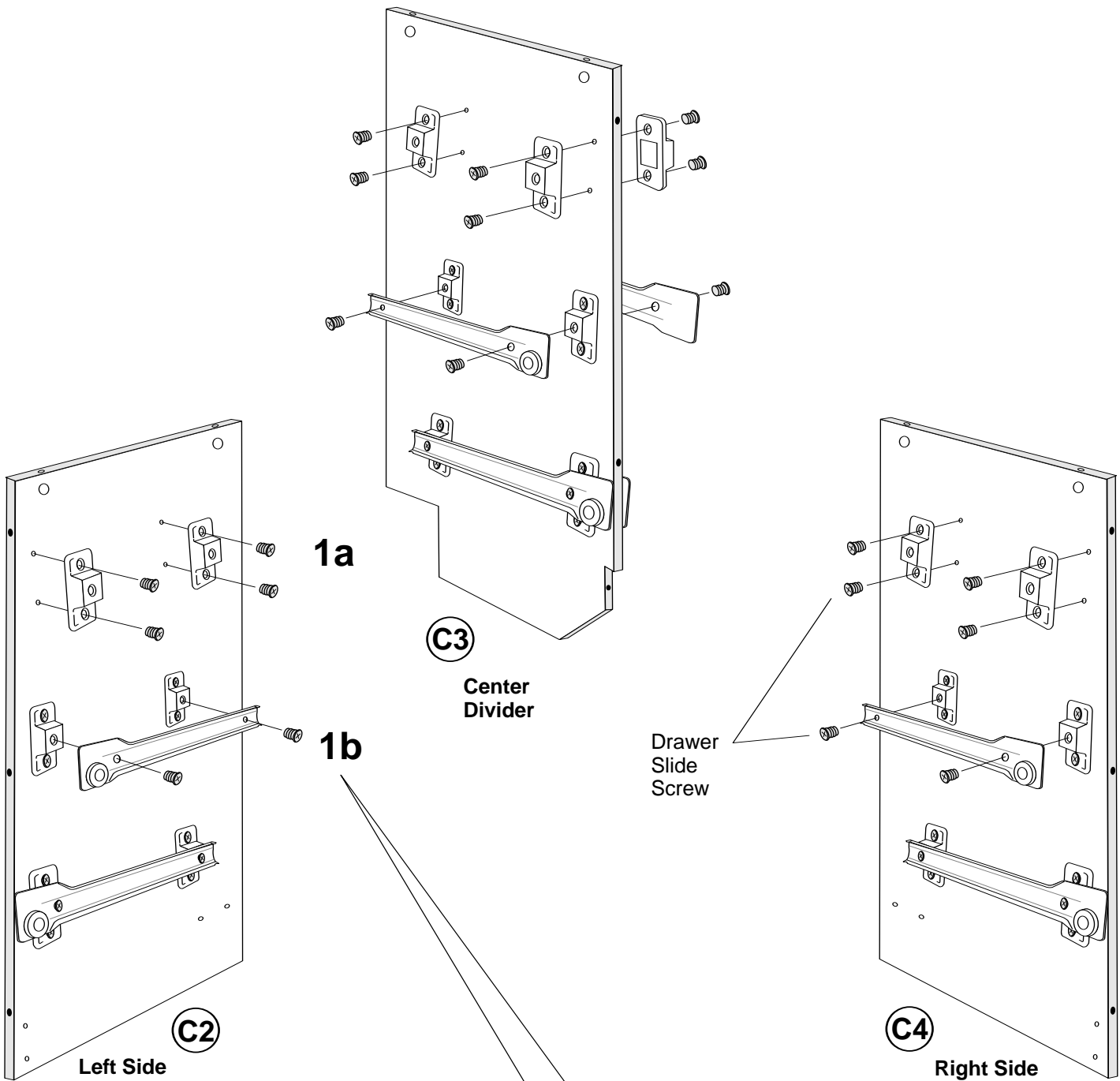

**STEP 2 Estimated Time: 1 minute**

Insert cams into holes on the top of each side

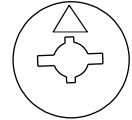
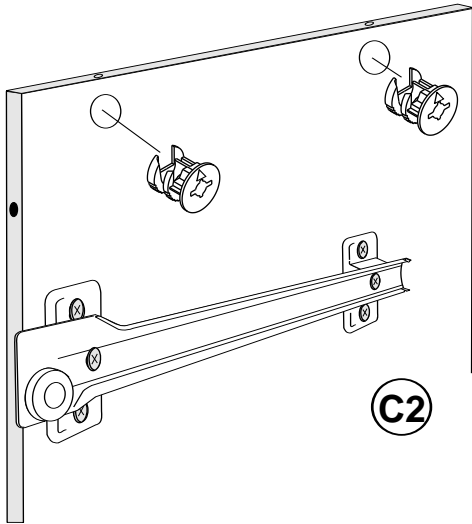

Make sure arrow on cam faces top

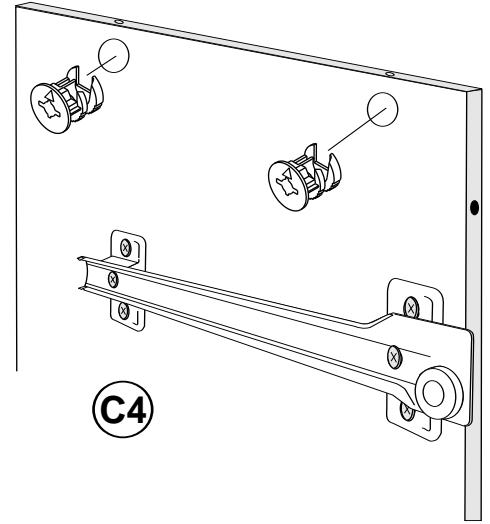

**STEP 3 Estimated Time: 1 minute**

On the center divider, insert cams where shown

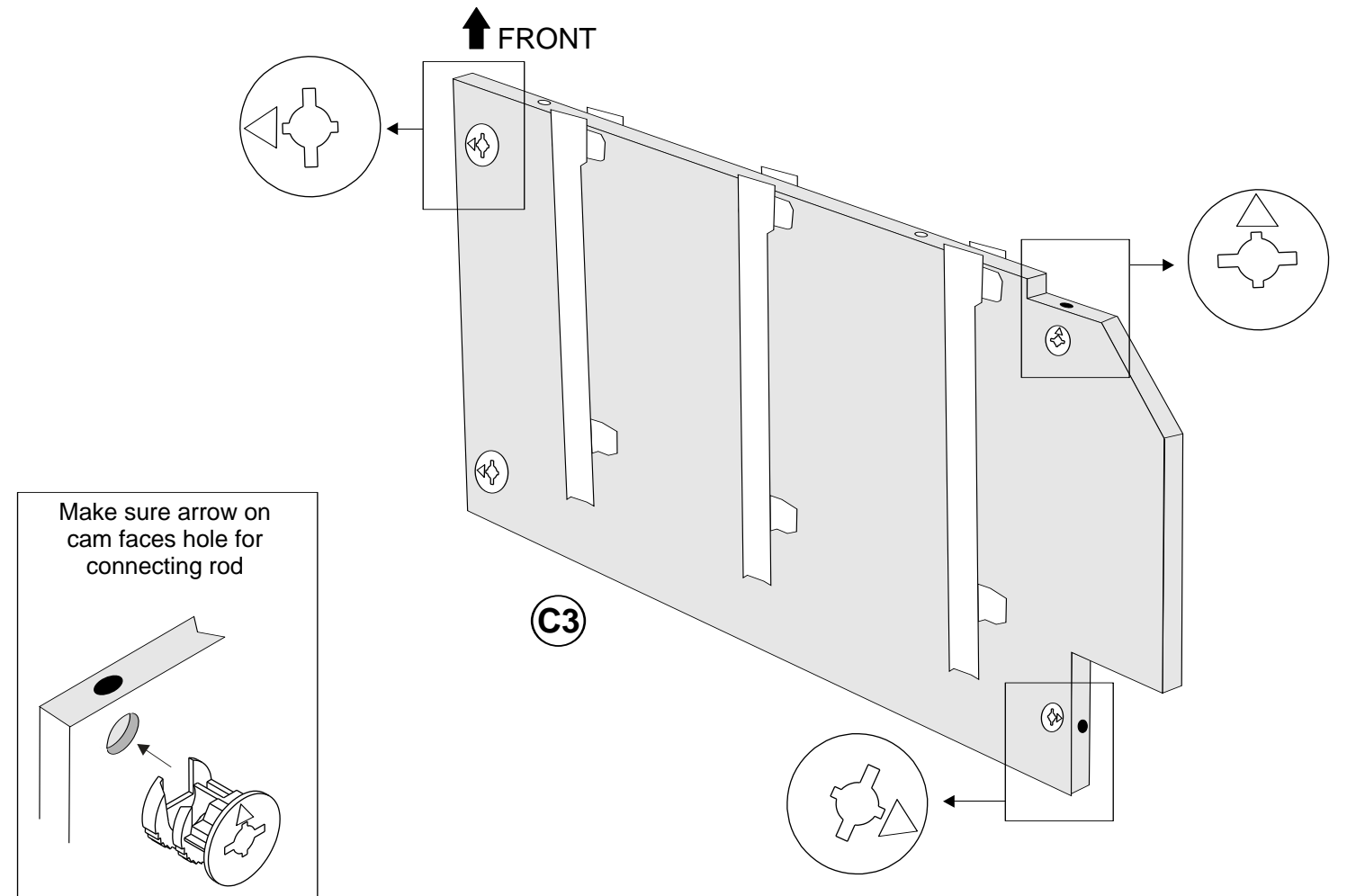

Make sure arrow on cam faces hole for connecting rod

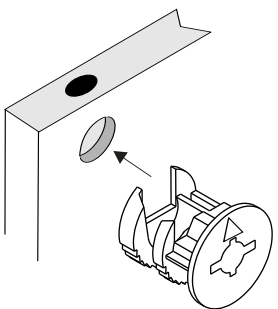

## STEP 4 Estimated Time: 1 minute

Insert Blue Rapid Rod into the center hole on each decorative stabilizer

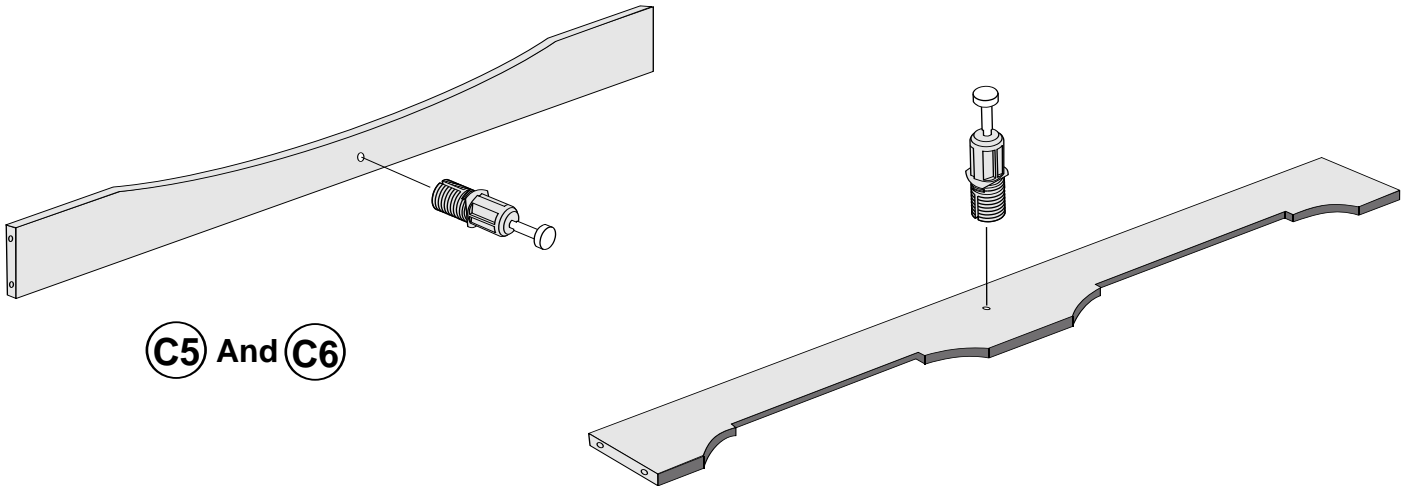

**C5** And **C6**

## STEP 5 Estimated Time: 5 minutes

Decorative stabilizers **C5** & **C6** are interchangeable.

- 5a** Choose the style that you prefer, and attach it to the front of the center divider
- 5b** Attach the remaining stabilizer to the back of the center divider
- 5c** Lock both cams with a flat head screwdriver

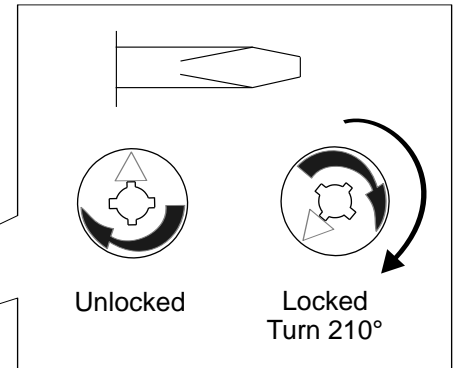
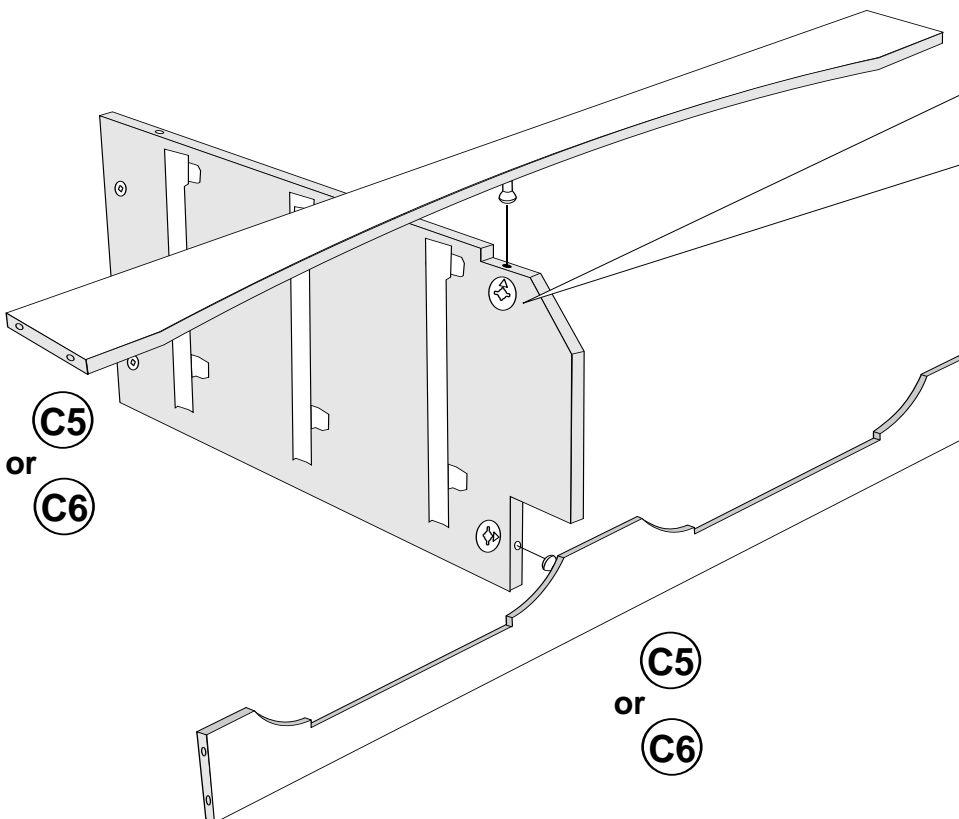

## STEP 6 Estimated Time: 10 minutes

Attach both stabilizers to left and right sides using Confirmat screws. Insert screw cover caps to finish.

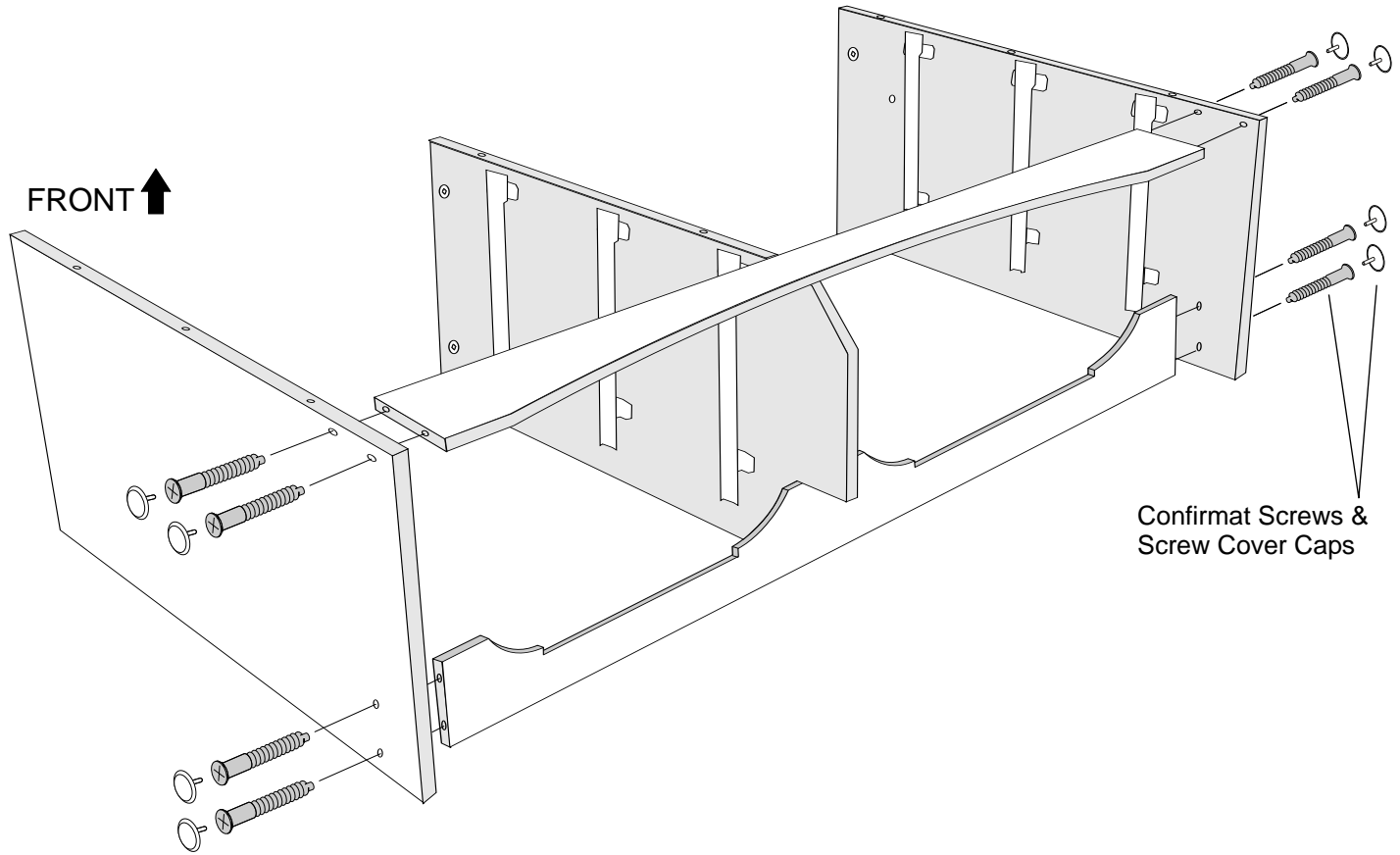

## STEP 7 Estimated Time: 3 minutes

Hammer plastic dowels halfway into side, center and top moldings

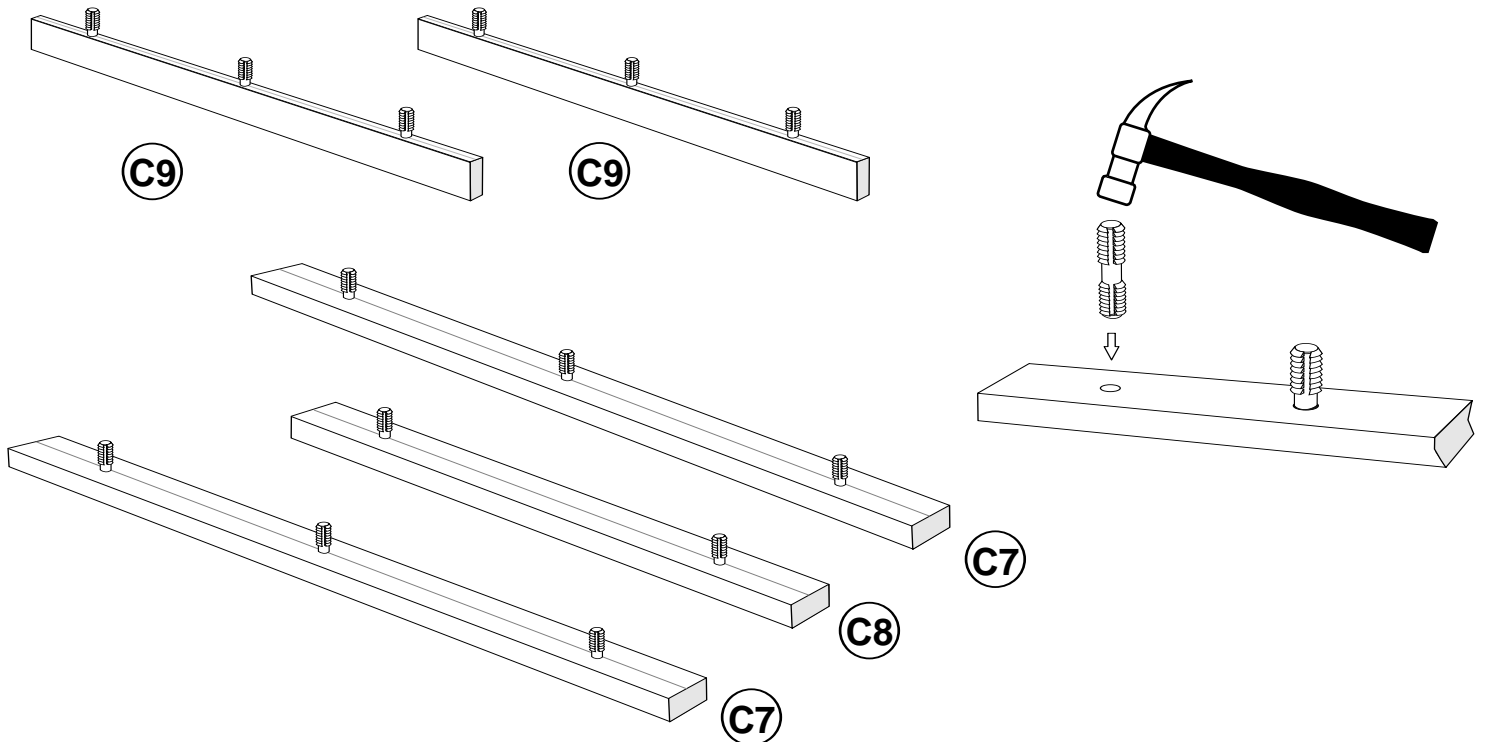

## STEP 8 Estimated Time: 2 minutes

Screw **green** twister dowels into the underside of the top

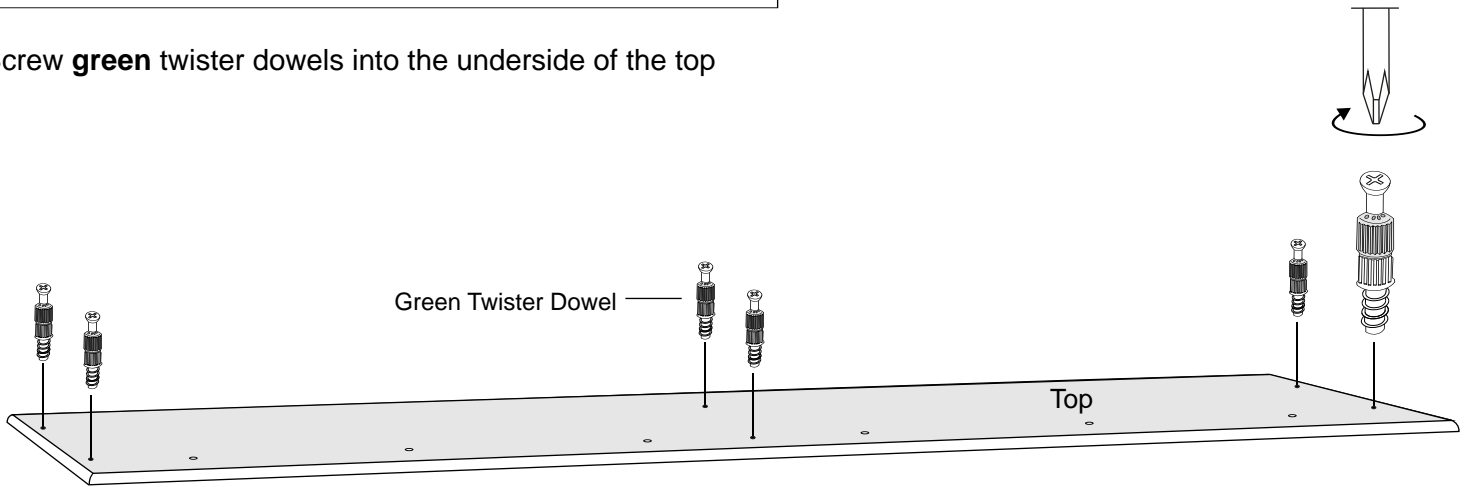

## STEP 9 Estimated Time: 2 minutes

Attach top to sides and lock cams using a flat head screwdriver

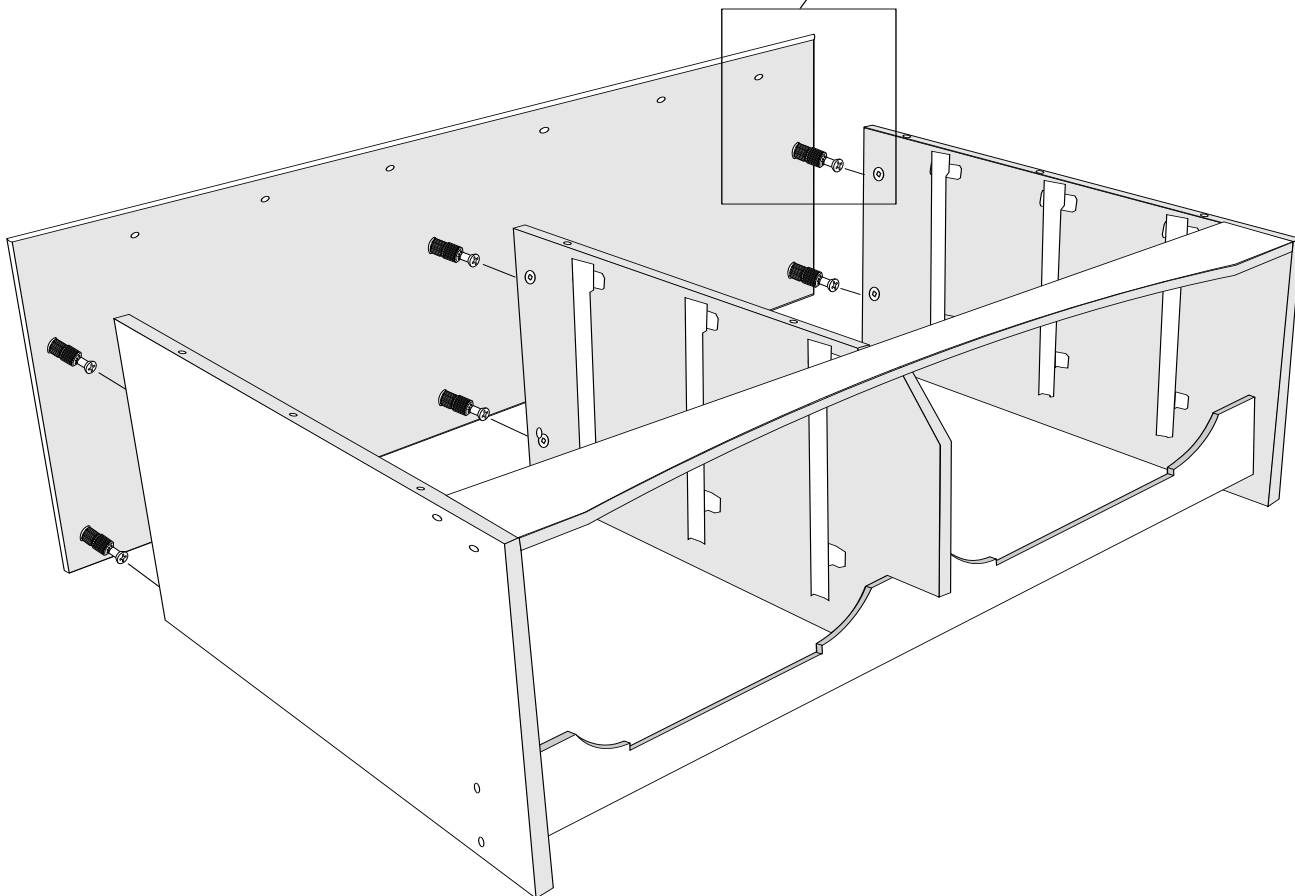
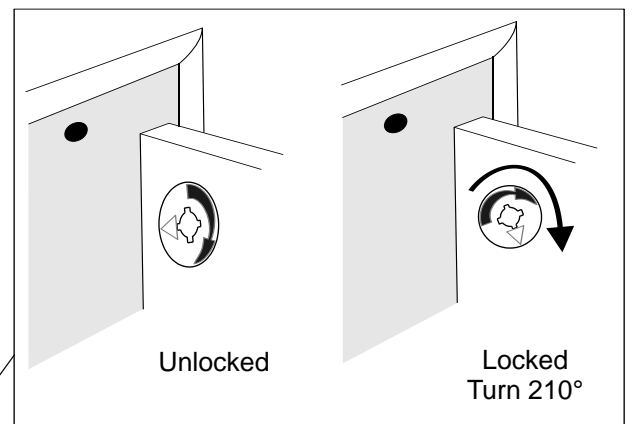
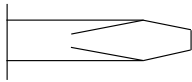



## STEP 10 Estimated Time: 3 minutes

Attach top & side moldings.  
Using your hands, apply even pressure to moldings and press firmly

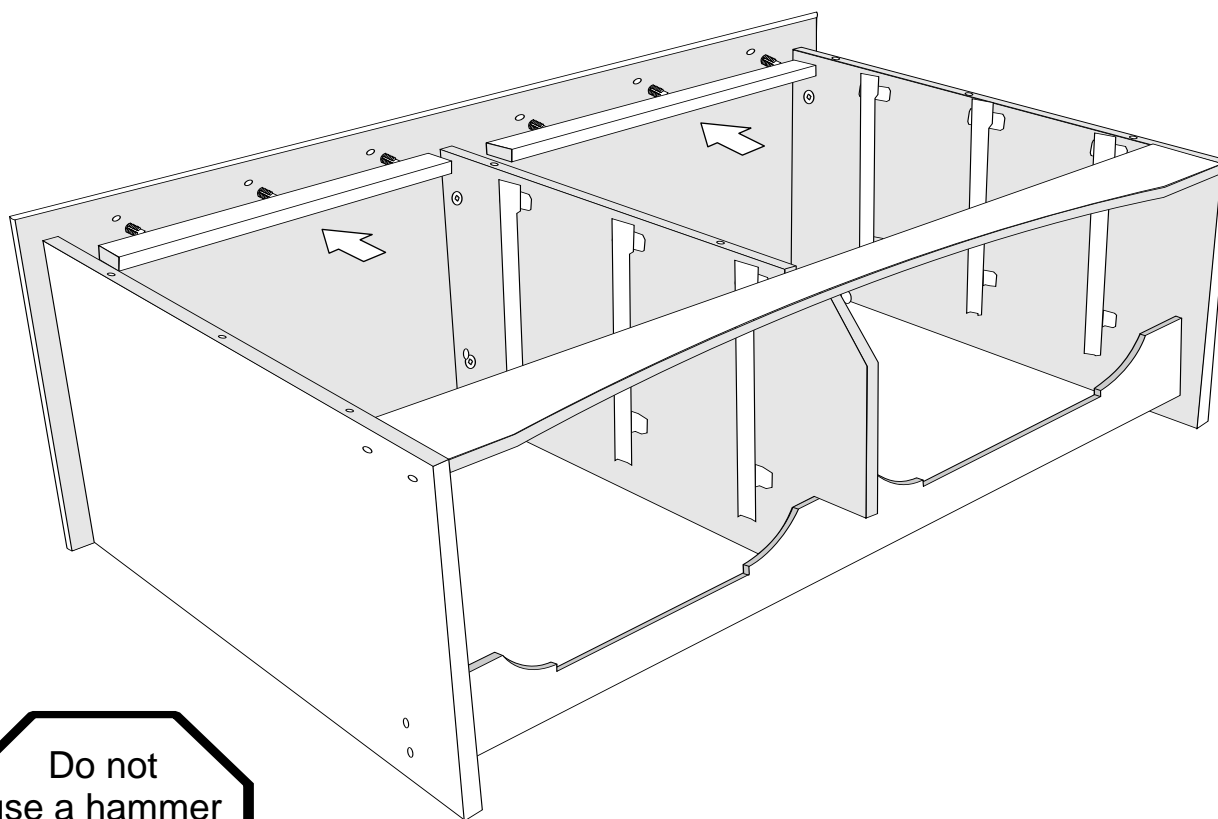

Do not  
use a hammer  
It may damage  
the molding

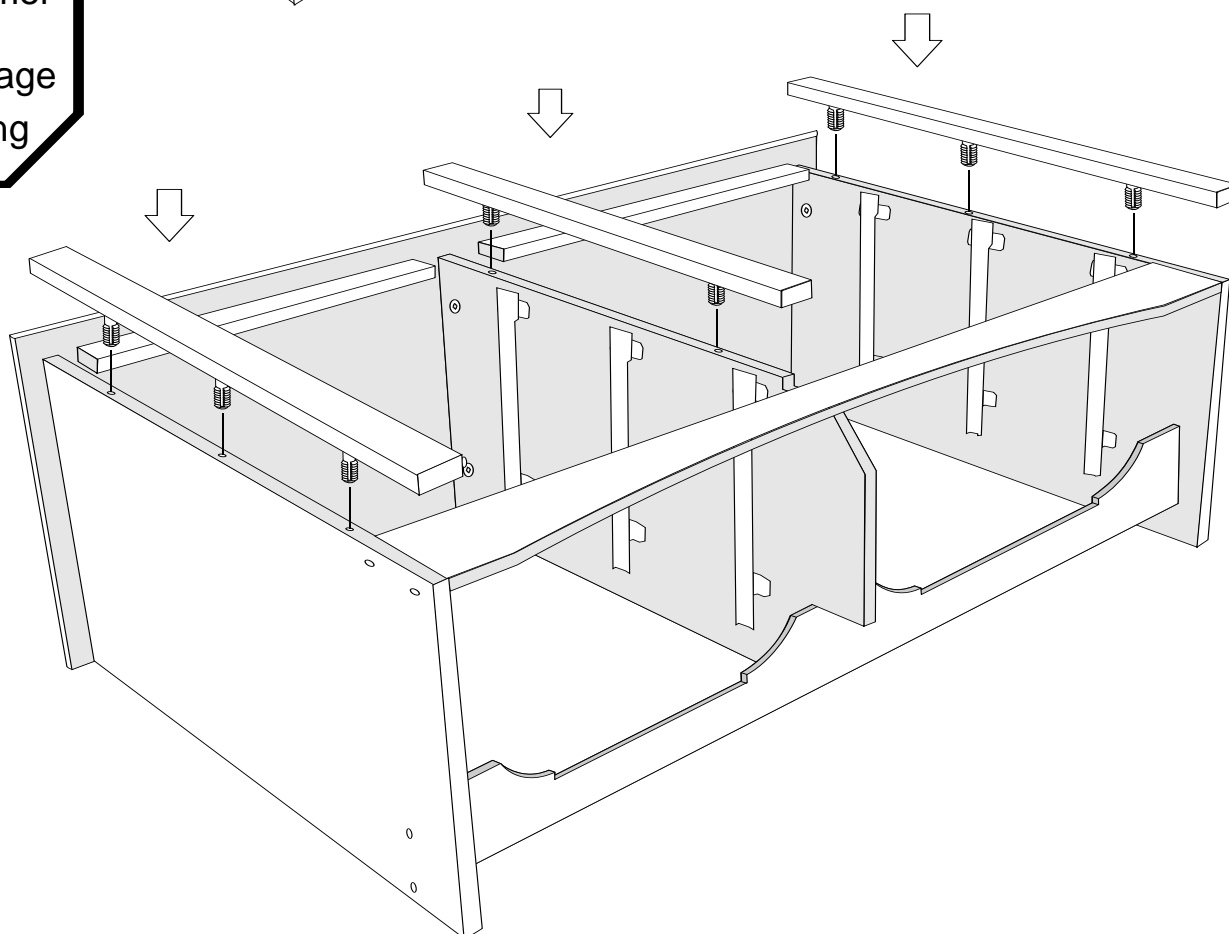

**STEP 11 Estimated Time: 4 minutes**

Carefully turn dresser over and attach backer

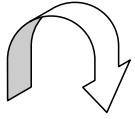

Nail backer as indicated. You may have more nails than are necessary

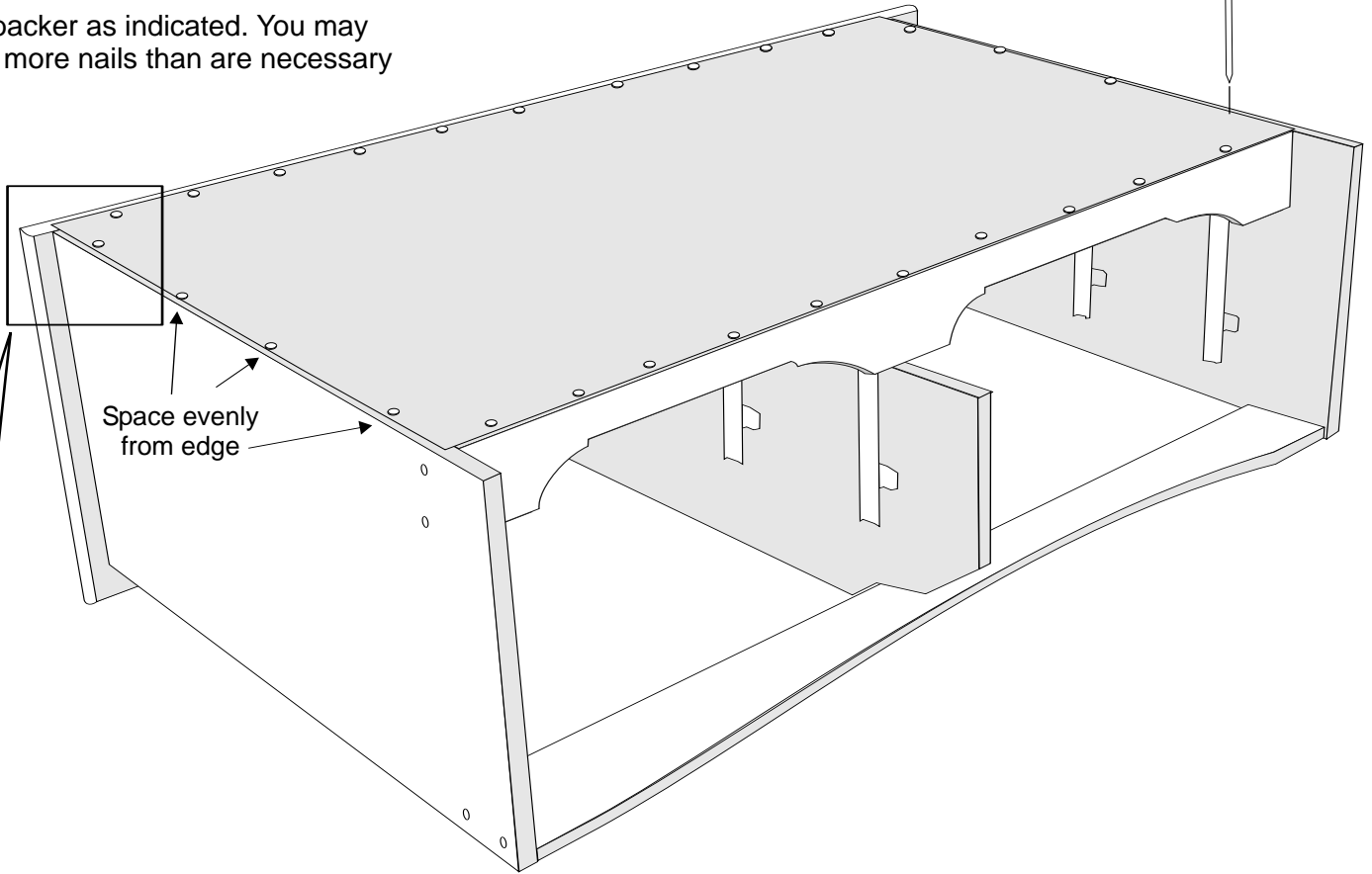

Space evenly from edge

Position nails in the center of the board

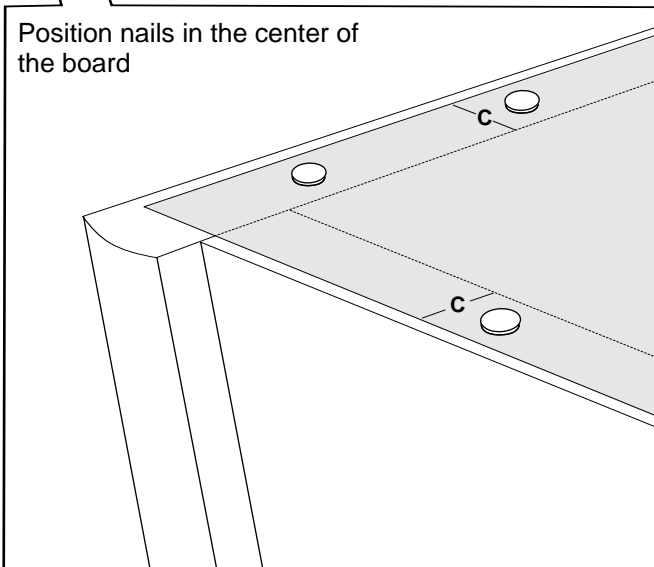

**NOTE:**  
Do not stand product up without the backer fastened

# Drawer Parts Identification

**D1**

Drawer Front (6)  
**DF-10014-B** black  
**DF-10017-C** cherry  
**DF-10014-E** espresso  
**DF-10014-M** maple  
**DF-10017-W** white

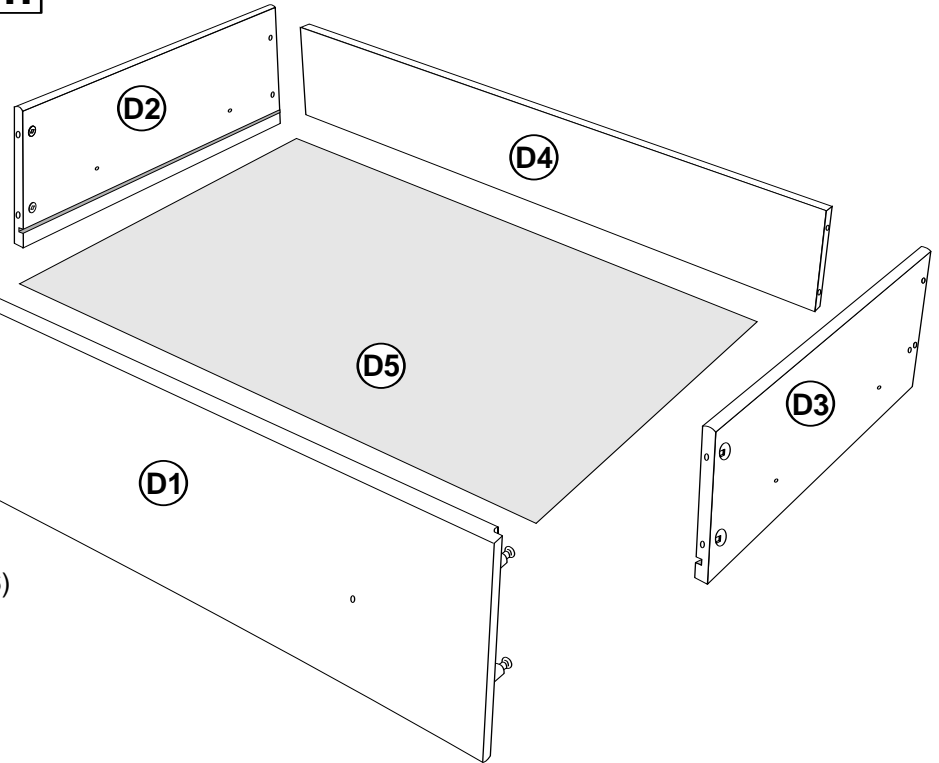

**D2**

Left Drawer Side (6)  
**DS-0412W-L**

**D3**

Right Drawer Side (6)  
**DS-0412W-R**

**D4**

Drawer Back (6)  
**DK-0415W**

**D5**

Drawer Bottom (6)  
**DB-0415**  
 Unfinished

## STEP 12 Estimated Time: 5 minutes PER DRAWER

### 12a Insert cams into drawer sides

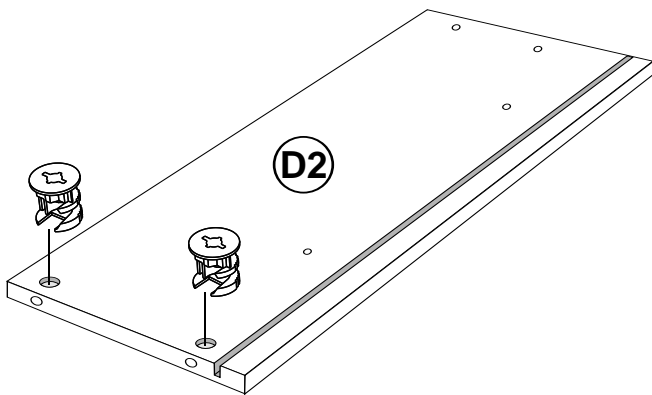

Left Drawer Side

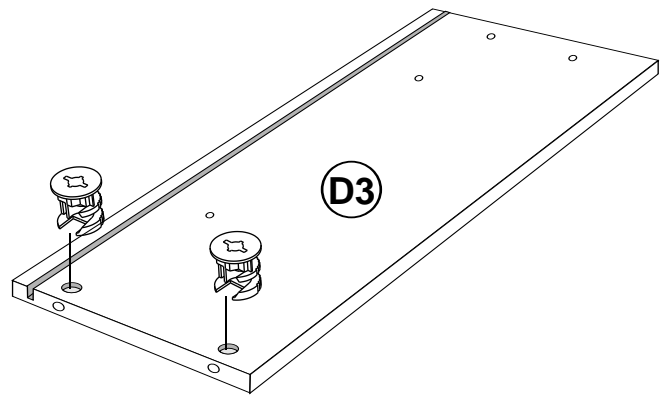

Right Drawer Side

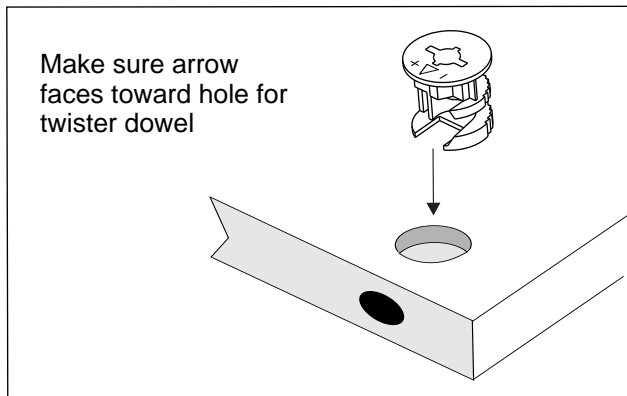

**12b** Screw **black twister** dowels into drawer fronts

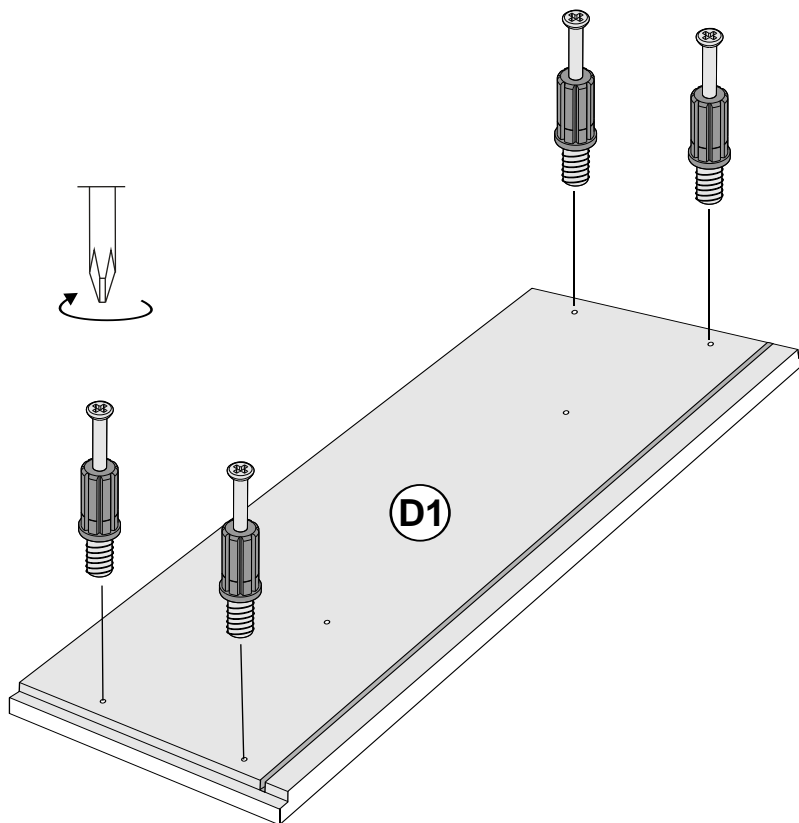

**12c** Attach drawer sides to drawer back with 1½" Hi Lo screws

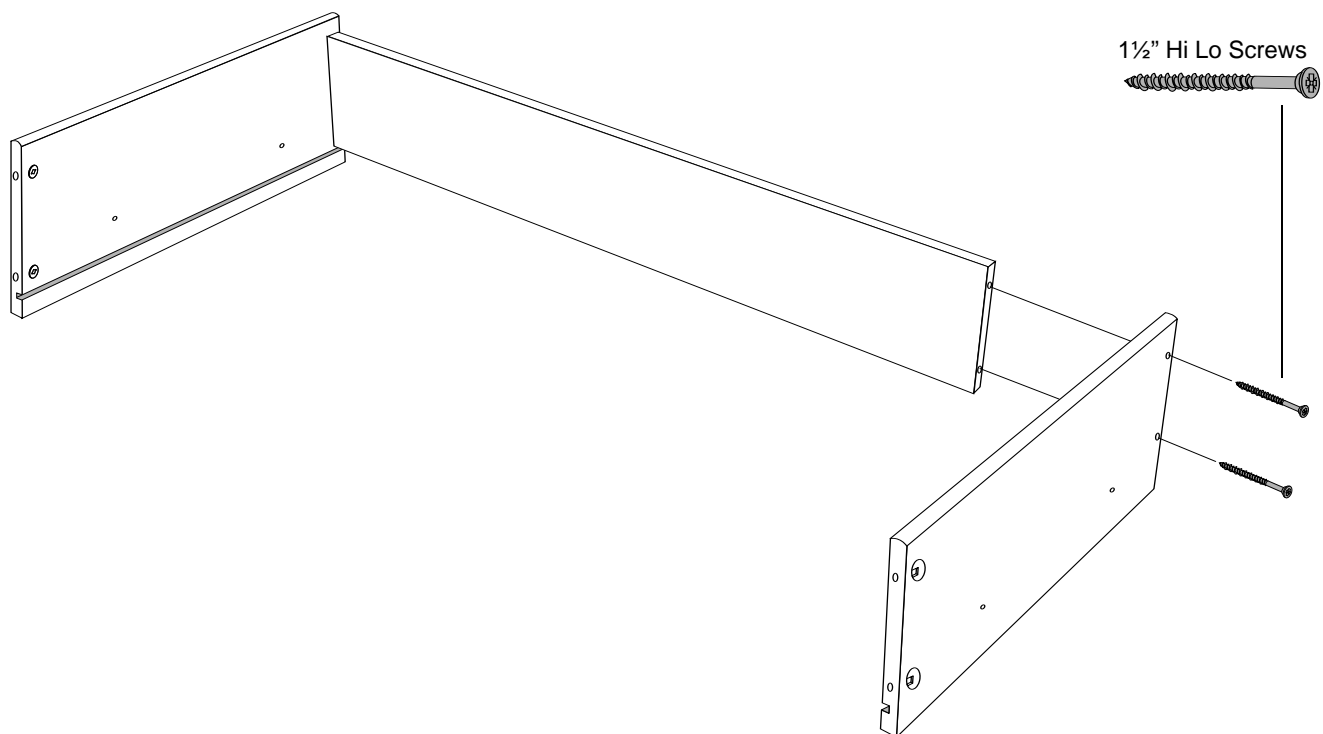

**12d** Attach drawer front and tighten cams using a flat head screwdriver

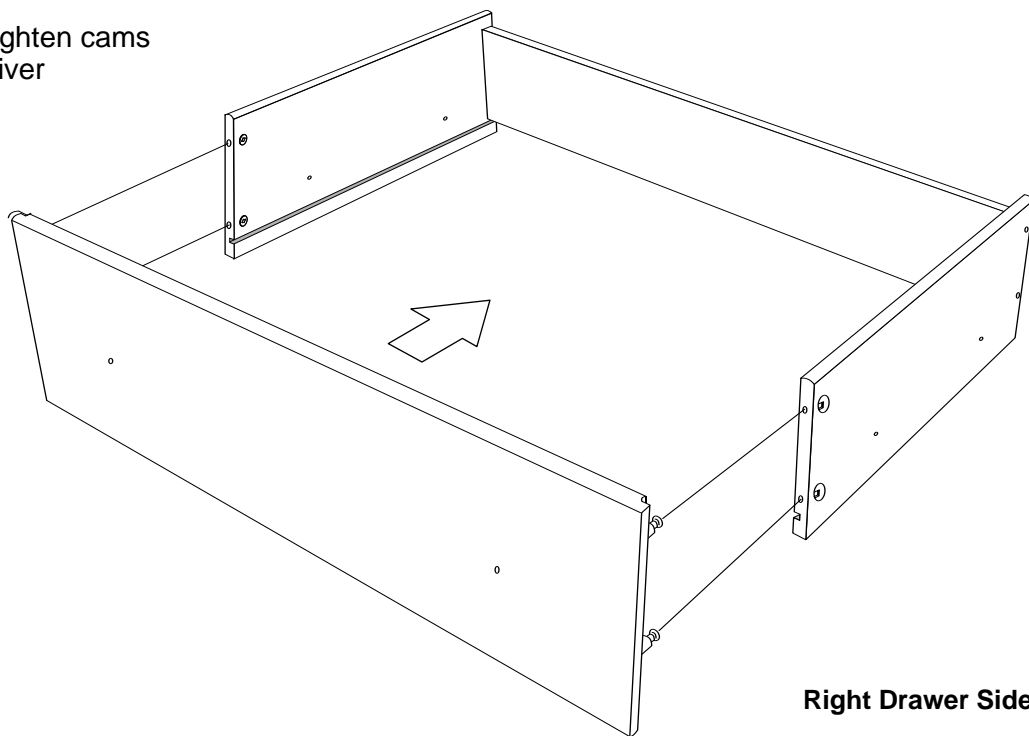
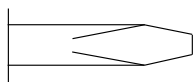

**Left Drawer Side**

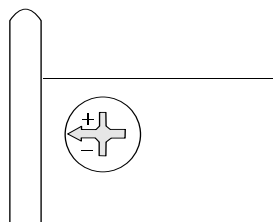

Unlocked

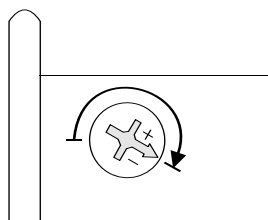

Locked  
Turn 210°

**Right Drawer Side**

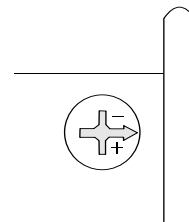

Unlocked

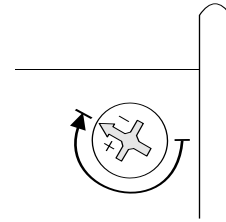

Locked  
Turn 210°

**12e** Turn drawer upside down and slide drawer bottom into grooves

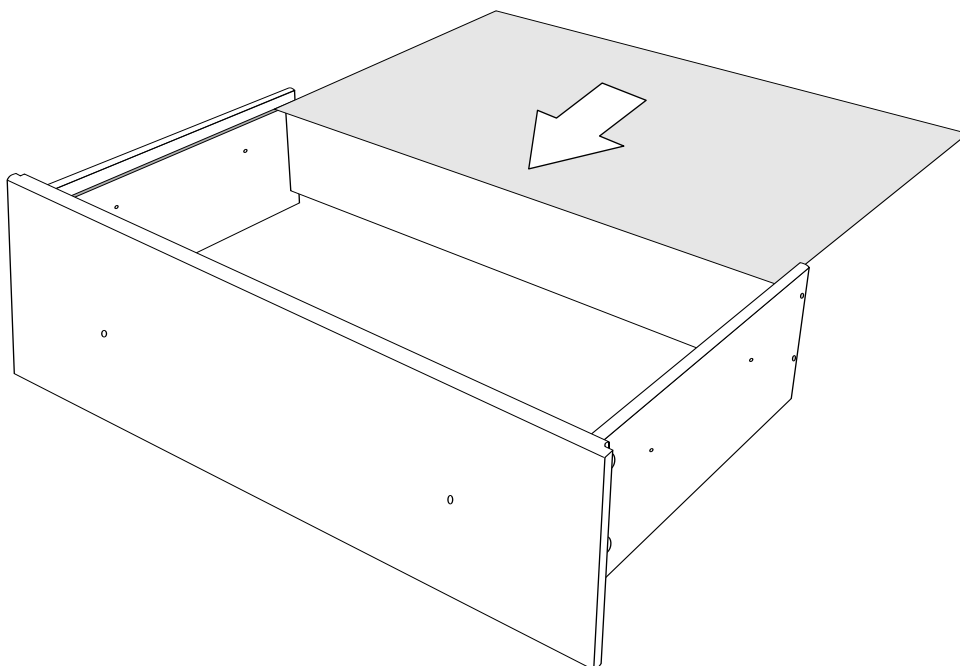
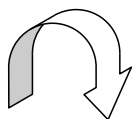

**12f** Secure the drawer bottom to the drawer back with nails

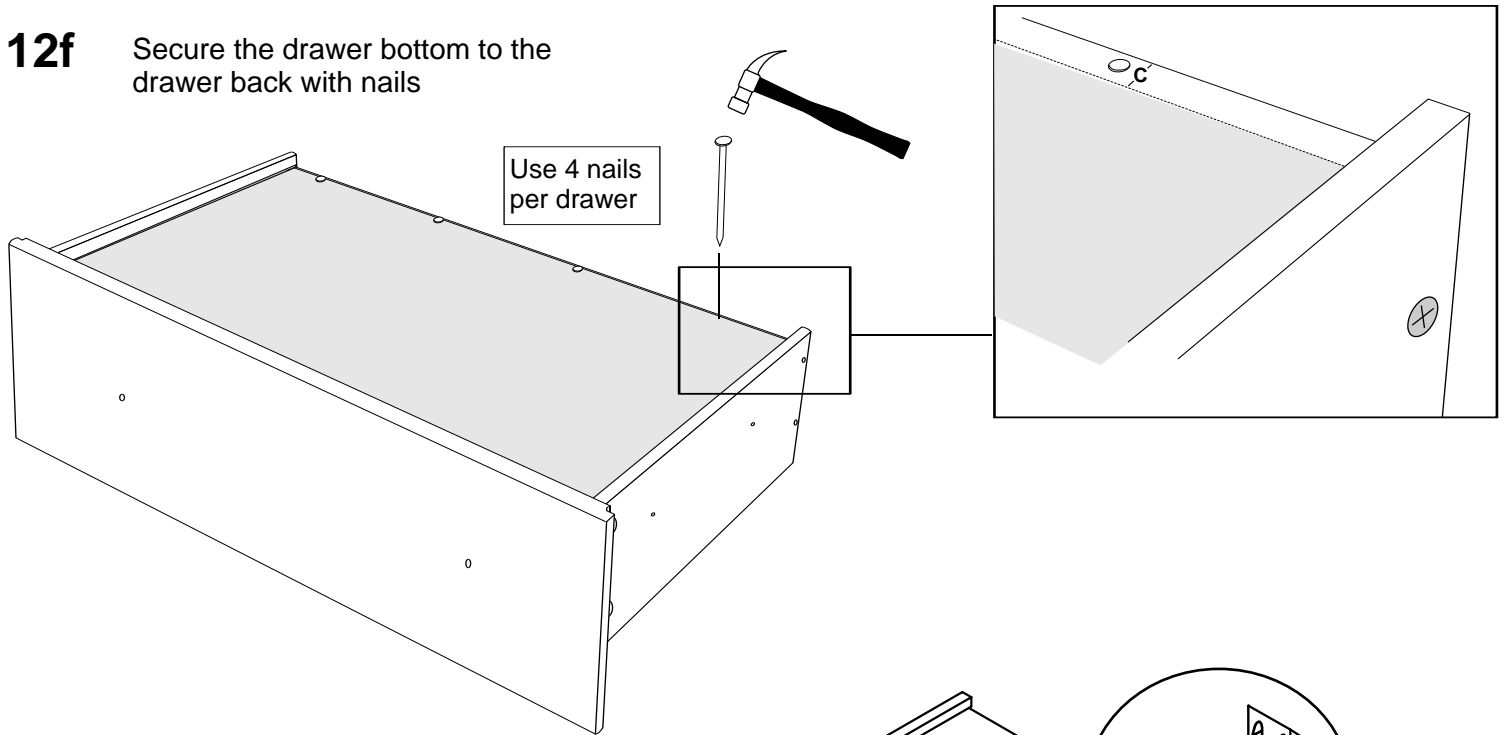

**12g** Insert the Drawer Bottom Stabilizer

Position the Stabilizer in the center of the drawer and insert it into the groove on the drawer front. This is the same groove that you inserted the drawer bottom into.

Then, tighten screw until it is flush

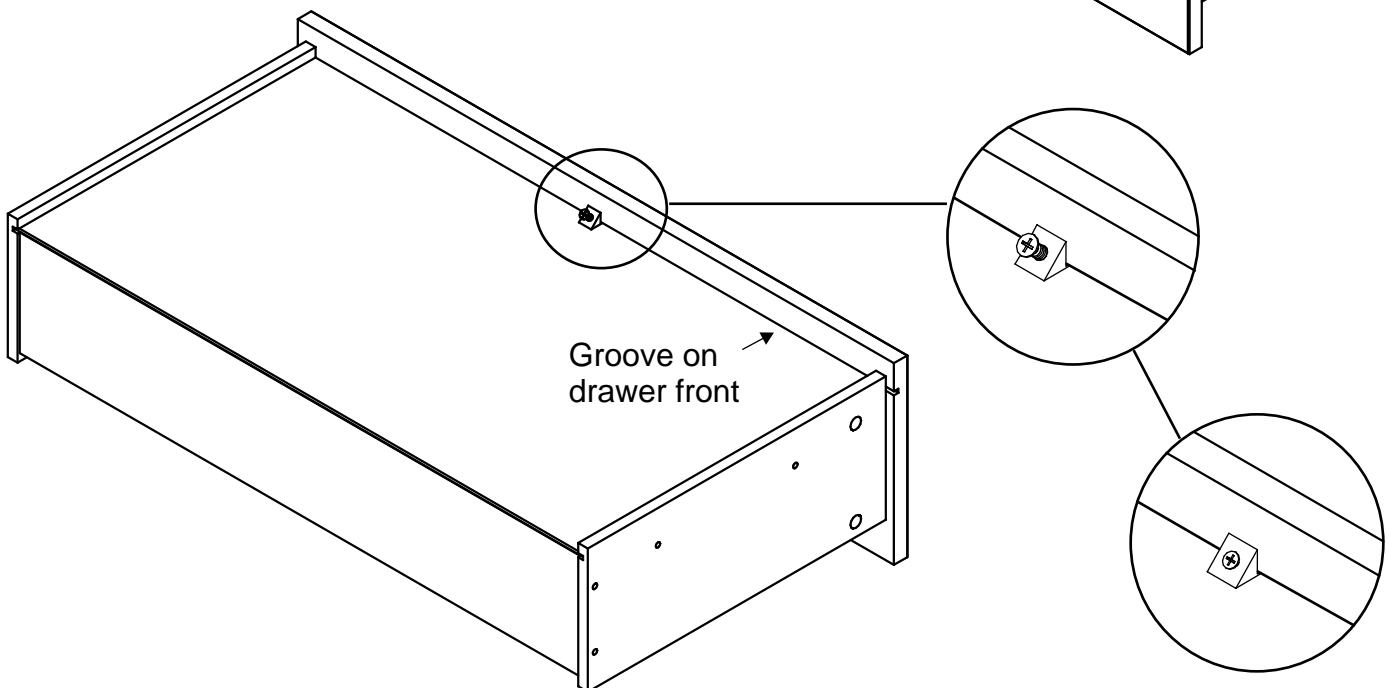
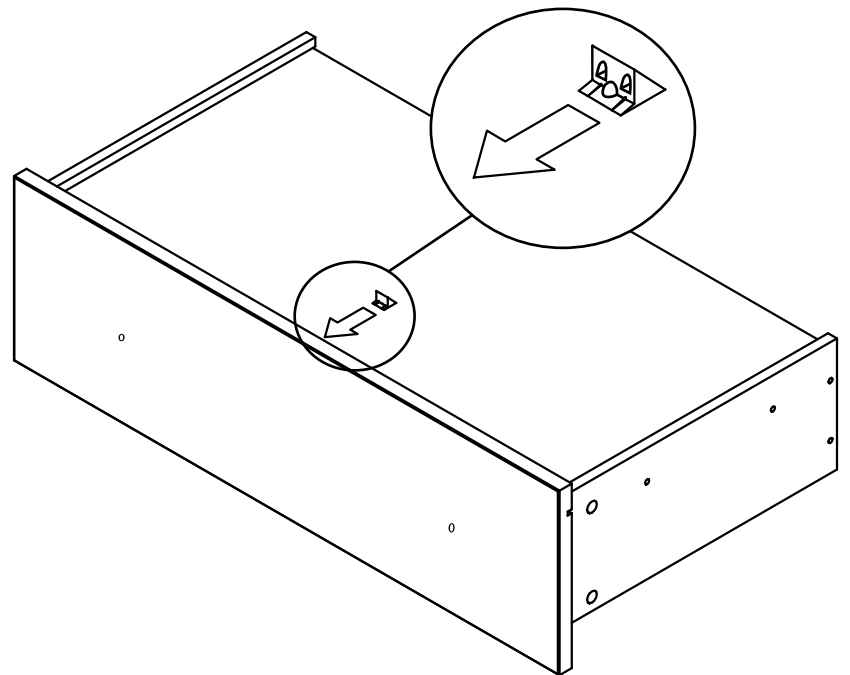

**12h** Attach drawer slides to left and right drawer sides using drawer slide screws

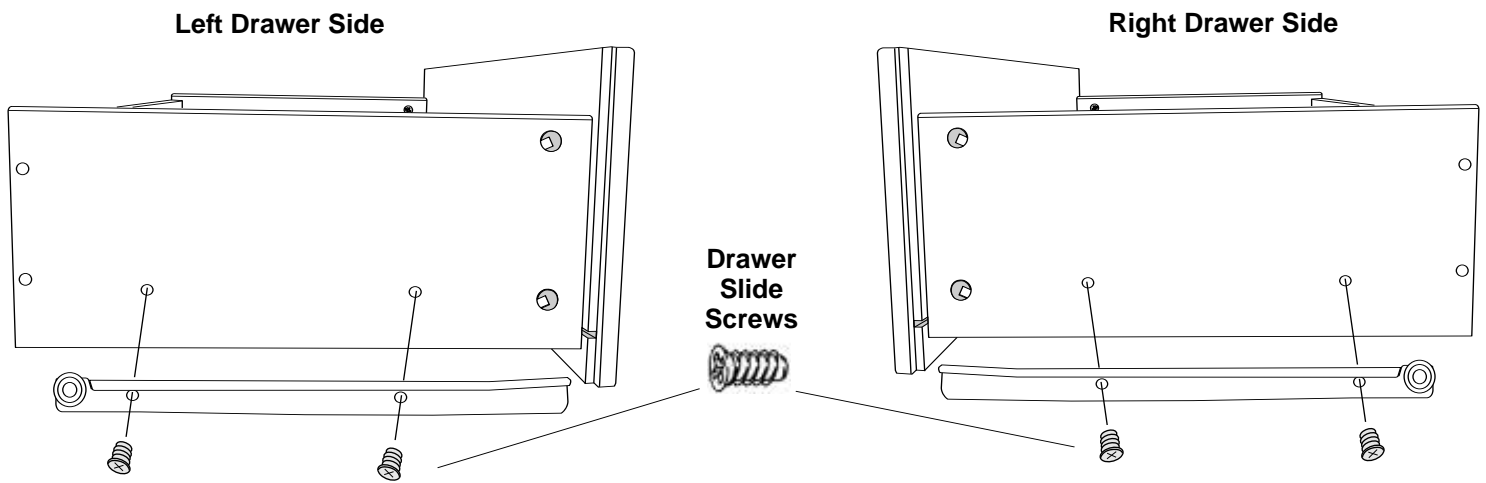

**12i** Attach knobs with machine screws

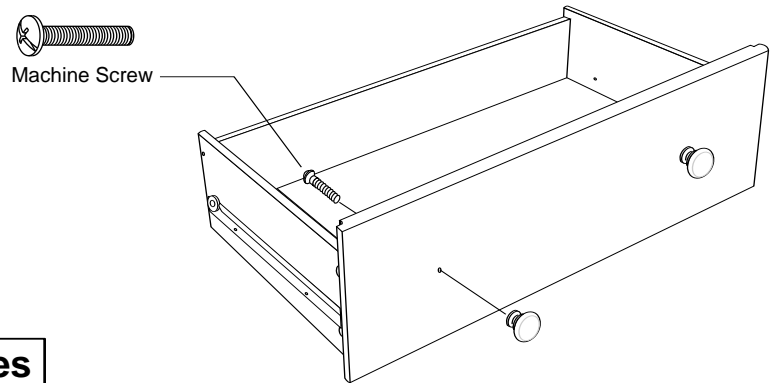

**STEP 13** Estimated Time: 2 minutes

Insert drawers

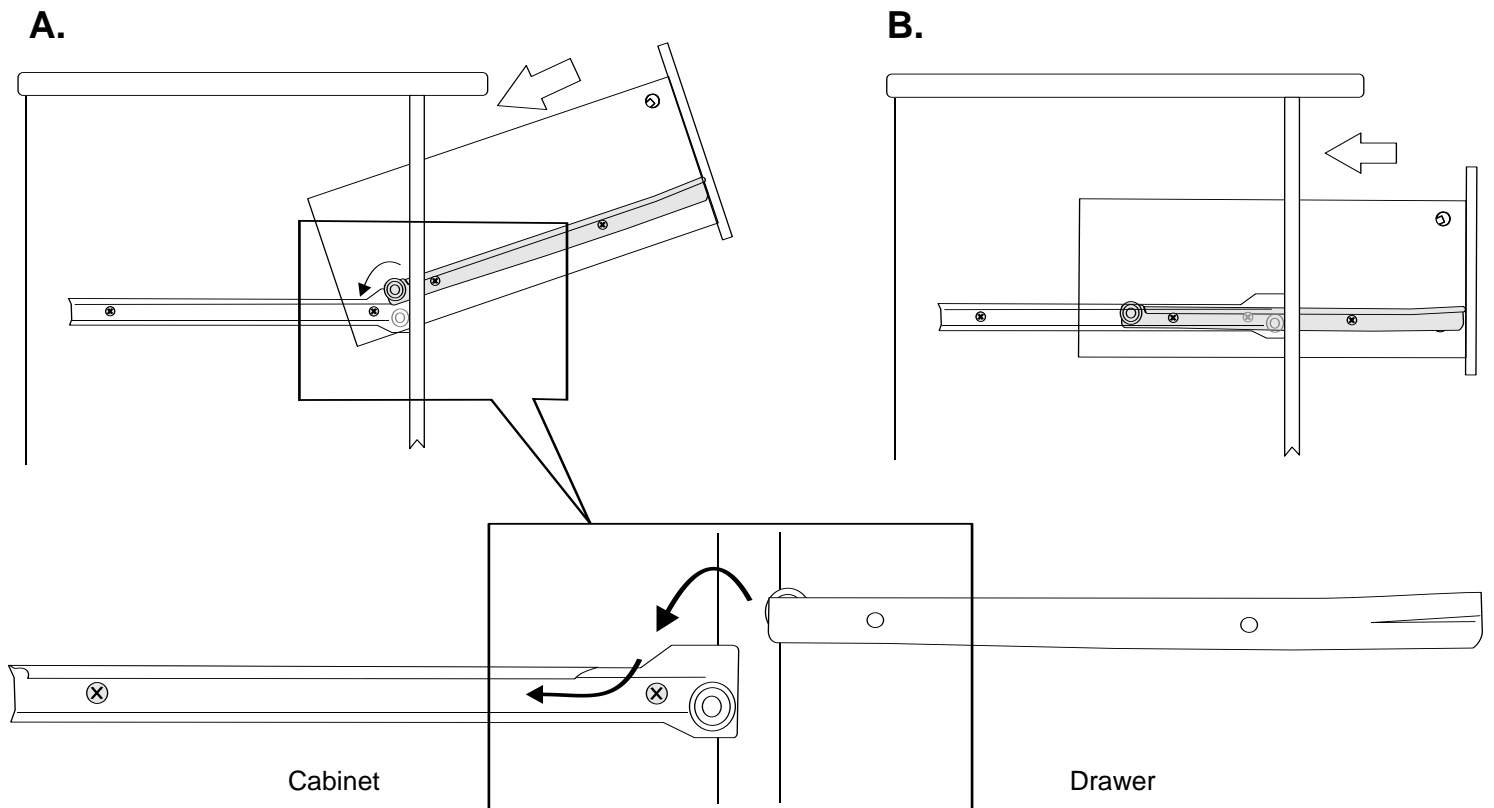

**Note:** When drawers are installed correctly, you will not be able to remove them without first lifting up the drawer front.

## STEP 14 Attaching and Using the Cable Tie

We strongly recommend using a cable tie on all furniture, especially if small children have access

**14a.** With the #6-3/4" screw, attach one of the mounting bases to one of the sides 1 inch from the top.

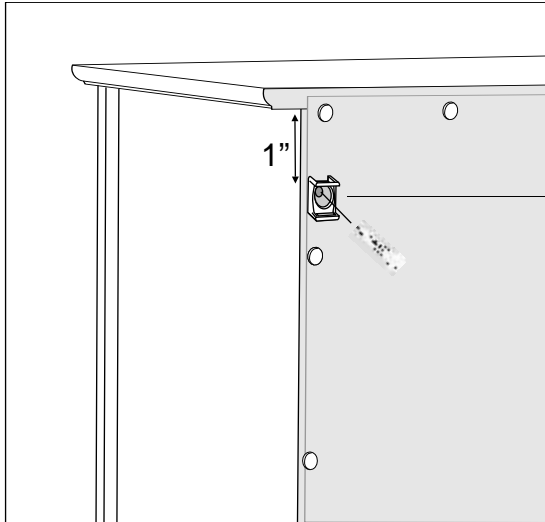

**14b.** Attach the 2nd mounting base to the wall 2" lower than the one on the cabinet

**Important:** Find a wall stud and attach the mounting base with a 1 1/2" screw (not included). If you cannot locate a stud, use an approved wall mounting system

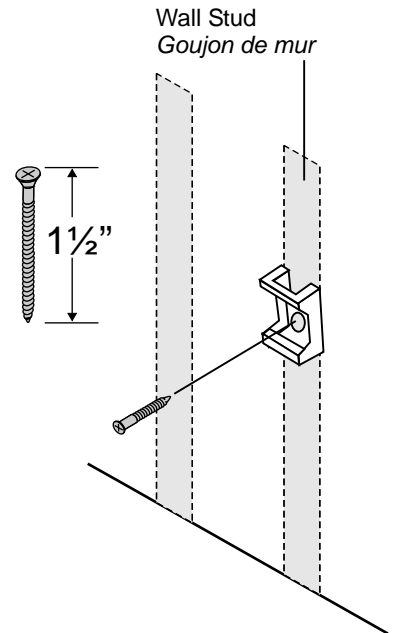
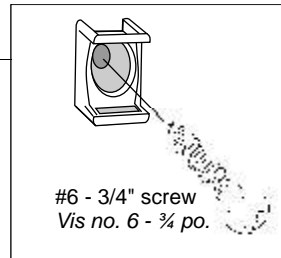

**14c.** Feed the cable tie through each mounting base and then through the locking mechanism to tighten.

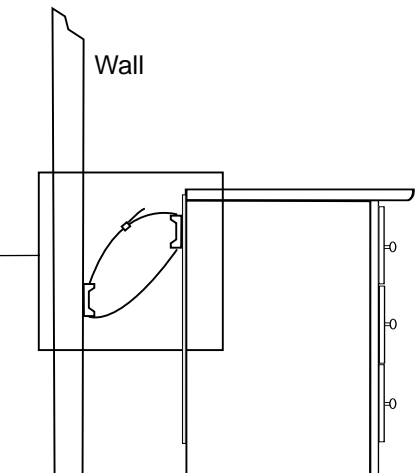
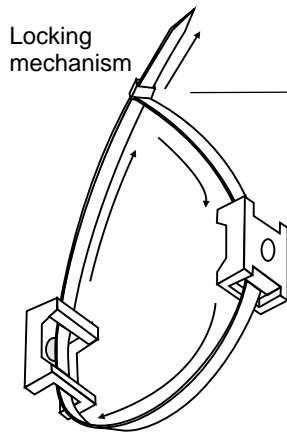

**Give Us Your Feedback**



**CALL US**

1-877-PREPAC1 (1-877-773-7221)

Mon - Fri 7am - 4pm PST

10am - 7pm EST

Email Us: [assembly@prepacmfg.com](mailto:assembly@prepacmfg.com)

**Thanks!**